

**685**  
**BEFORE THE HON'BLE NATIONAL GREEN TRIBUNAL**  
**PRINCIPLE BENCH AT NEW DELHI**  
**APPEAL NO. 13 OF 2026**  
**(I.A. NO. 150/2026 & I.A. NO. 151/2026)**

**IN THE MATTER OF:**

M/s Punahchakran Private Limited

...Applicant

Versus

Uttar Pradesh State Environment Impact  
Assessment Authority & Ors.

...Respondent(s)

**Index**

Sr. No.	Particulars	Page no.
1.	<b>Reply on behalf of Central Pollution Control Board, (CPCB) respondent no. 5</b> in compliance to Hon'ble NGT order dated 09.03.2026 in Appeal No. 13 of 2026 (I.A No. 150/2026 & I.A No. 151/2026)	
2.	<b>Annexure –I</b> A copy of letter dated 20.02.2017 issued by CPCB to DGAFMS, SPCBs/PCCs and CBWTF Association.	
3.	<b>Annexure-II</b> A copy of letter dated 16.04.2025 issued by CPCB to all SPCBs/PCCs.	
4.	<b>Annexure-III</b> A copy of guidelines issued by CPCB dated 21.12.2016.	
5.	<b>Annexure-IV</b> A copy of guidelines issued by CPCB dated 12.04.2025.	
6.	<b>Annexure-V</b> A copy of letter dated 10.10.2023 issued by CPCB to all SPCBs/PCCs.	
7.	<b>Annexure-VI</b> A copy of letter dated 12.12.2024 issued by CPCB to all SPCBs/PCCs.	
8.	<b>Annexure-VII</b> A copy of direction dated 11.12.2024 issued by CPCB to all SPCBs/PCCs.	



**Filed by Adv. Atif Suhrawardy**  
**On behalf of Central Pollution Control Board**

**Place: Delhi**  
**Dated:12.05.2026**

**BEFORE THE HON'BLE NATIONAL GREEN TRIBUNAL  
PRINCIPLE BENCH AT NEW DELHI  
APPEAL NO. 13 OF 2026  
(I.A. NO. 150/2026 & I.A. NO. 151/2026)**

**IN THE MATTER OF:**

M/s Punahchakran Private Limited ...Applicant

Versus

Uttar Pradesh State Environment Impact  
Assessment Authority & Ors. ...Respondent(s)

**REPLY ON BEHALF OF CENTRAL POLLUTION CONTROL  
BOARD (RESPONDENT NO. 5)**

**MOST RESPECTFULLY SHOWETH:**

**PRELIMINARY SUBMISSIONS:**

1. That the Answering Respondent herein, CPCB, has been constituted under Section 3 of the Water (Prevention and Control of Pollution) Act, 1974. It performs the functions under the Water (Prevention and Control of Pollution) Act, 1974 (hereinafter referred to as " Water Act, 1974"), the Air (Prevention and Control of Pollution) Act, 1981 (hereinafter referred to as " Air Act, 1981") and the Environment (Protection) Act, 1986.
2. That the State Pollution Control Boards (hereinafter referred to as "SPCBs") and Pollution Control Committees (hereinafter referred to as "PCCs") have been constituted in States/Union Territories under the Water Act, 1974 and the Air Act, 1981 and are empowered to implement the provisions of these Acts in respect of their Territorial Jurisdictions.



3. The present appeal has been filed under Section 16(h) of the National Green Tribunal Act, 2010, challenging the **Environmental Clearance dated 24.12.2025** granted by the Uttar Pradesh State Environment Impact Assessment Authority (UP SEIAA) to **M/s Indo Tech Waste Solution** for establishing a Common Bio-Medical Waste Treatment Facility in Village Kumraua, District Kasganj, Uttar Pradesh.

The Appellant alleges that the clearance has been granted in violation of the EIA Notification, 2006, the Revised Guidelines for Common Bio-Medical Waste Treatment and Disposal Facilities, 2016, and orders of the Hon'ble National Green Tribunal dated 22.03.2024 (passed in Appeal No. 13/2023) and 21.01.2025 (passed in Appeal No. 27/2024).

4. That, it is humbly submitted that the Biomedical Waste Management Rules, 2016 (hereinafter referred to as "BMWM Rules, 2016") have been notified by the Ministry of Environment, Forest and Climate Change (hereinafter referred to as "MoEF & CC") for the management of biomedical waste in an environmentally sound manner. As per Rule 9(1) of the BMWM Rules, 2016, the prescribed authority for the implementation of the provisions of these rules shall be the State Pollution Control Boards in respect of States and Pollution Control Committees in respect of Union territories.
5. That, it is humbly submitted that this Answering Respondent has prepared various Guidelines on bio-medical waste management from time-to-time, including the Guidelines for **Common Biomedical Waste Treatment and Disposal Facilities** (hereinafter referred to as, "CBWTF") in December 21, 2016 and as amended on April 12, 2025.

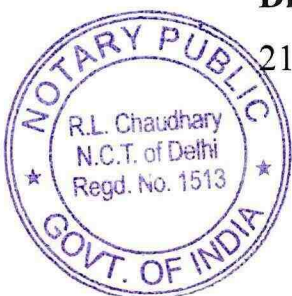

The said Guidelines for CBWTF were prepared by CPCB with an aim to have uniformity in ensuring site selection, allowing and establishment of state-of-the-art CBWTFs, operation, as well as verification of compliance with the BMWM Rules, 2016 throughout the country.

The said Guidelines also stipulate the Criteria for development of a new Common Bio-medical Waste Treatment and Disposal Facility for a locality or region. As per para 2 of the guideline issued in December 21, 2016:

*"2) Criteria for development of a new Common Biomedical Waste Treatment and Disposal Facility for a locality or region.*

*Prior to allowing any new CBWTF, following criteria or steps may be followed:*

*a) Prescribed authority under the BMWM Rules, 2016 (i.e., SPCB in the respective State or PCC in the respective Union Territory Administration) is required to prepare an inventory or review with regard to the bio-medical waste generation at least once in five years in the coverage areas of the existing bio-medical waste treatment and disposal facility. The prescribed authority is also required to extrapolate the coverage area wise bio-medical waste generation for the next ten years.*

*b) SPCB/PCC is required to conduct gap analysis w.r.t coverage area of the bio-medical waste generation and also projected over a period of next ten years, adequacy of existing treatment capacity of the CBWTF in each coverage area of radius 75 KM, as given in Annexure-I. All the SPCBs and PCCs shall conduct the gap analysis and based on the gap analysis, action plan for development of new CBWTFs is*



*required to be prepared and submitted to MoEF&CC & CPCB within six months' time. In case of States/UTs, where no CBWTF is available, in such a case, SPCB/PCC being prescribed authority under the BMW Rules is required to submit the detailed proposal to MoEF & CC/MoH & FW through the respective State Government or UT Administration. Also, the option of forming association by the group of health care facilities (HCFs) to develop their own CBWTF also be encouraged following these guidelines. In case, any coverage area requires additional treatment capacity, in such a case, action may be initiated by the prescribed authority for allowing a new CBWTF in that locality without interfering the coverage area of the existing CBWTF and beds covered by the existing CBWTF.*

*c) SPCB/PCC shall identify the coverage area, which require additional treatment facility and bring it to the notice of the concerned department in the business allocation of land assignment in the respective State Government or UT Administration. The department in the business allocation of land assignment shall be responsible for providing suitable site in the identified coverage area for setting up of a CBWTF, in consultation with the prescribed authority (i.e., SPCB/PCC), other stakeholders and in accordance with these guidelines issued by CPCB from time to time.*

*d) Alternately, a CBWTF may also be allowed to be established on a land procured by an entrepreneur in accordance with the location criteria suggested under these guidelines. ..."*



The aforesaid guideline has been **amended in April 12, 2025** wherein the aforesaid para 2 remained same **except that methodology for conducting gap analysis** was also provided in the guidelines vide sub para (b) of the said para 2 of the guideline and the said sub para (b) of para 2 of the said guidelines amended in April 2025 reads as below:

*"2) Criteria for development of a new Common Biomedical Waste Treatment and Disposal Facility for a locality or region.*

*Prior to allowing any new CBWTF, following criteria or steps may be followed:*

*"...b ) SPCB/PCC is required to conduct gap analysis w.r.to coverage area of the bio-medical waste generation, its projection over a period of next ten years, adequacy of existing treatment capacity of the CBWTF in each coverage area of radius 75 KM, as given in Annexure-I and as per methodology for conduct of gap analysis given at Appendix-I of the guidelines. Further, decision may be taken by concerned SPCB/PCC based on gap analysis report to allow new facility or expansion of an existing facility. Adequacy of the existing facility to handle quantum of biomedical waste and/or compliance with the norms prescribed under BMWM Rules, 2016 shall also be taken into account. All the SPCBs and PCCs shall conduct the gap analysis and based on the gap analysis, action plan for development of new CBWTFs is required to be prepared and submitted to MoEF & CC & CPCB within six months' time. In case of States/UTs, where no CBWTF is available, in such a case, SPCB/PCC being prescribed authority under the BMWM Rules is required to ensure establishment new facilities. SPCB/PCC may submit*



*the detailed proposal to MoEF & CC/MoH & FW through the respective State Government or UT Administration. Association of HCFs may also be encouraged to develop their own CBWTF following these guidelines. In case, any coverage area requires additional treatment capacity, in such a case, action may be initiated by the prescribed authority for allowing a new CBWTF in that locality based on the gap analysis report without interfering the coverage area of the existing CBWTF. ...."*

6. Further, the Guidelines also stipulate the coverage area of CBWTF. As per Para 8 of the guideline issued on December 21, 2016:

*"8) Coverage area of CBWTF*

*Suggested coverage area for development of a CBWTF is as follows:*

*a) A CBWTF located within the respective State/UT shall be allowed to cater healthcare units situated at a radial distance of 75 KM. However, in a coverage area where 10,000 beds are not available within a radial distance of 75 KM, existing CBWTF in the locality (located within the respective State/UT) may be allowed to cater the healthcare units situated up to 150 KM radius w.r.to its location provided the bio-medical waste generated is collected, treated and disposed of within 48 hours as stipulated under the BMWM Rules.*

*b) In case, number of beds is exceeding >10,000 beds in a locality (i.e. coverage area of the CBWTF under reference) and the existing treatment capacity is not adequate, in such a case, a new CBWTF may be allowed in such a locality in*



*compliance to various provisions notified under the Environment (Protection) Act, 1986, to cater services only to such additional bed strength of the HCFs located.*

*c) In case of hilly areas, considering the geography, only one CBWTF with adequate treatment capacity may be developed covering at least two districts to cater treatment services to the HCFs located in the respective Districts. The selection and allocation of site etc. should be done as per the criteria suggested under these guidelines. The treatment charges to be prescribed by the respective SPCB/PCC in consultation with the State Advisory Committee to be constituted under the BMWM Rules by the respective State Government or UT Administration.”*

The aforesaid Guidelines were amended on April 12, 2025, whereby paragraph 8 was revised.

In the **amended Guidelines**, the provisions relating to **coverage area** up to 150 km and the number of beds stipulated under sub-paragraphs (a) and (b) of paragraph 8 of the Guidelines dated December 21, 2016, have been amended.

Further, provision for conducting gap analysis in cases of capacity shortfall or noncompliance with the Bio-medical Waste Management Rules, 2016, is added to enable the concerned SPCB/PCC to consider the establishment of a new CBWTF or expansion of the existing facility. The revised subparagraph (a) of paragraph 8 of the Guidelines, as amended on April 12, 2025, reads as under:

“8) Coverage area of CBWTF

*Suggested coverage area for development of a CBWTF is as follows:*



- a. A CBWTF located within the respective State/Union Territory may be allowed to cater to healthcare units situated within a radial distance of 75 kilometers, subject to the condition that the facility possesses adequate treatment capacity to handle the biomedical waste generated within the said radius. For the purpose of determining adequacy, 90% of the total treatment capacity as authorized by the concerned SPCB or PCC shall be considered. It shall further be ensured that bio-medical waste generated is collected, treated and disposed of within 48 hours as stipulated under the BMWM Rules. The concerned SPCB/PCC shall undertake a gap analysis, as per Appendix-I, to assess the quantum of bio-medical waste generated vis-à-vis the available treatment capacity of the CBWTF (considering 90% of the authorized treatment capacity). In case the analysis indicates a shortfall in treatment capacity or if the existing CBWTF is found to be non-compliant with the provisions of the Bio-Medical Waste Management Rules, 2016, the SPCB/PCC may consider proposals for establishing a new CBWTF or for expansion of an existing facility, ensuring that bio-medical waste generated is collected, treated and disposed of within 48 hours as stipulated under the BMWM Rules.

7. That, it is humbly submitted that the guidelines issued by the CPCB on 21.12.2016 and 12.04.2025 also stipulate the applicability provisions of the guidelines vide para 4 of the guidelines, and the same are as below:

*“4) Applicability of these guidelines*

*These guidelines are applicable to all the upcoming or new CBWTFs. In case of the existing CBWTFs, these guidelines shall be applicable*

- (a) the existing CBWTFs desires to expand or enhance the existing treatment capacity (or)*



*(b) the existing CBWTFs desires to modernize the existing treatment equipment with the new equipment with enhancement in the existing treatment capacity.”*

8. It is humbly submitted that the answering respondent i.e. CPCB, has already communicated to all SPCBs/PCCs vide letters dated 20.02.2017 and 16.04.2025 to ensure implementation of the CPCB guidelines issued on December 21, 2016 and April 12, 2025, respectively.

The true copy of the CPCB letters dated 20.02.2017 was sent to SPCBs/PCCs to ensure the implementation of the CPCB guidelines is marked and annexed hereto as **Annexure-I**.

The true copy of the CPCB letters dated 16.04.2025 was sent to SPCBs/PCCs to ensure the implementation of the CPCB guidelines is marked and annexed hereto as **Annexure-II**.

The true copy of the CPCB guidelines issued on December 21, 2016, has been marked and annexed hereto as **Annexure-III**.

The true copy of the CPCB guidelines issued on April 12, 2025, has been marked and annexed hereto as **Annexure-IV**.

9. That, it is humbly submitted that the answering respondent prepared the methodology to conduct gap analysis with respect to the generation and treatment of biomedical waste in order to avoid ambiguity and maintain uniformity for conducting gap analysis.

The said methodology has been circulated to all SPCBs/PCCs vide letter dated 10.10.2023, with a request to conduct gap analysis w.r.t. generation and treatment of biomedical waste using the said methodology and also to submit a report in this regard to CPCB.



A true copy of the letter dated 10.10.2023 circulated to all SPCBs/PCCs, with a request to conduct gap analysis w.r.t. generation and treatment of biomedical waste using the said methodology and also to submit a report in this regard to CPCB, has been marked and annexed as **Annexure-V**.

10. That, it is humbly submitted that in compliance with the CPCB's letter, dated 10/10/2023, some SPCBs/PCCs conducted gap analysis and submitted the report to CPCB. However, the reports submitted by SPCBs/PCCs showed non-uniformity and ambiguity specifically with regard to the method for extrapolating the data on biomedical waste generation and the requirement of adequate treatment capacity.

Therefore, this Answering Respondent has prepared **revised methodology** titled "**Methodology to Conduct gap analysis with respect to generation and treatment of biomedical waste - Revision 1**" with an aim to have uniformity in the method for carrying out the gap analysis by SPCBs/PCCs. CPCB vide letter dated 12/12/2024 requested all SPCBs/PCCs to conduct/revise gap analysis w.r.t. generation and treatment of bio-medical waste in the concerned State/UT using the revised methodology and directed to submit a report to CPCB within one month.

The same revised methodology has also been included as Appendix-I in the aforesaid CPCB guideline issued in April 2025, which was communicated to all SPCBs/PCCs vide the aforesaid letter on 16.04.2025 to ensure its implementation.

A true copy of the CPCB vide letter dated 12.12.2024 requested all SPCBs/PCCs to conduct/revise gap analysis w.r.t. generation and treatment of bio-medical waste has been marked and annexed as **Annexure-VI**.

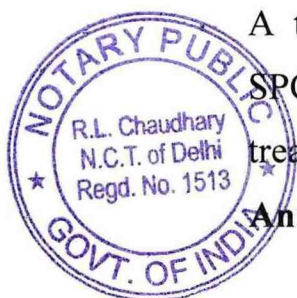

11. That, CPCB has also issued direction under Section 5 of the Environment (Protection) Act, 1986 to the Chairman of all SPCBs/PCCs on 11.12.2024 to ensure that there is no gap in biomedical waste generation and treatment by ensuring adequate numbers/capacity of treatment facilities in the State/UT and submit gap analysis report to CPCB with respect to biomedical waste generation and treatment of biomedical waste.

A true copy of the CPCB direction dated 11.12.2024 has been marked and annexed as **Annexure-VII**.

**PARA WISE REPLY**

12. That the averment made in para 1 is related to the purpose of filing the appeal and needs no comments by the answering respondent.

13. That the averment made in paras 2 and 3 is related to details of the petitioner unit & its coverage area and needs no comments by the answering respondent.

14. That the averments made in paragraphs 4.1 to 4.12 related to the processing of the Environmental Clearance (EC) application of Respondent No. 6 by Respondent No. 1. It requires no comment by the answering respondent.

15. That the averments made in paragraphs 4.13 to 4.17 related to the complaint submitted by the Applicant to Respondent No. 1 against Respondent No. 6. It requires no comment by the answering respondent.

16. That the averments made in paragraphs 4.18 to 4.23 pertain to the first appeal filed by Respondent No. 6 before the Hon'ble National Green Tribunal (Appeal No. 13/2023), challenging the Order dated 11.05.2023

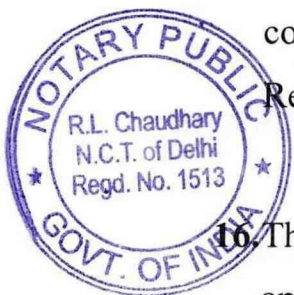

passed by SEIAA, Uttar Pradesh, rejecting the Environmental Clearance (EC) application of Respondent No. 6, as well as the proceedings before the Hon'ble Tribunal and the actions taken by Respondent No. 1. The same are matters of record and, therefore, require no comments from the answering Respondent.

17. That the averments made in paragraphs 4.24 to 4.31 pertain to another appeal filed by Respondent No. 6 before the Hon'ble National Green Tribunal (Appeal No.27/2024) challenging the minutes of the meeting/directions dated 17.05.2024 of SEIAA, UP which rejected the EC of respondent no. 6, as well as the proceedings before the Hon'ble Tribunal and the actions taken by Respondent No. 1. The same are matters of record and, therefore, require no comments from the answering Respondent.

18. That the averments made in paragraphs 4.32 to 4.35 pertain to the Execution Application No. 47/2025 in Appeal No. 27/2024 filed before the Hon'ble National Green Tribunal, as well as the proceedings before the Hon'ble Tribunal and the actions taken by Respondent No. 1. The same are matters of record and, therefore, require no comments from the answering Respondent.

19. That the averments made in paragraph 4.36 pertain to the allegation of the Applicant that the Environmental Clearance dated 24.12.2025 granted to Respondent No. 6 is based on the Terms of Reference (ToR) dated 11.06.2021 and the Final Environmental Impact Assessment (EIA) Report and Environmental Management Plan (EMP) prepared in July 2022. The same may be suitably reply by the concern respondent and it require no comments from this answering respondent.

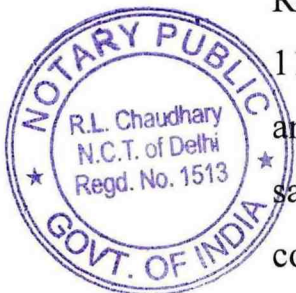

20. The averments raised in the grounds of the appeal merely reiterate the statements already addressed in the preceding paragraphs of this reply and, therefore, require no separate response. The same are denied for the reasons stated hereinabove.

21. That in addition to the aforesaid submissions, it is therefore submitted that this answering Respondent shall abide by any/all orders or directions passed by this Hon'ble Tribunal.



**Runa Oraon**  
**Scientist 'E'**

**Central Pollution Control Board**

**12.05.2026**

**BEFORE THE HON'BLE NATIONAL GREEN TRIBUNAL  
PRINCIPLE BENCH AT NEW DELHI  
APPEAL NO. 13 OF 2026  
(I.A. NO. 150/2026 & I.A. NO. 151/2026)**

**IN THE MATTER OF:**

M/s Punahchakran Private Limited ...Applicant

Versus

Uttar Pradesh State Environment Impact  
Assessment Authority & Ors. ...Respondent(s)

**AFFIDAVIT**

I, Runa Oraon S/o Late Shri Bigna Oraon, aged about 42 years, currently working as Scientist "E" in Central Pollution Control Board, Parivesh Bhawan, East Arjun Nagar, Delhi – 110032, the Respondent No. 5 in the aforesaid matter (hereinafter referred to as "CPCB" or "the Answering Respondent") do hereby solemnly affirm and declare as under:

1. That I, the deponent herein, is well conversant with the facts and circumstances of the present case on the basis of the information derived from the official records, and hence, I am competent to verify, sign and swear this affidavit on behalf of the Respondent CPCB.
2. That the accompanying reply may be read part and parcel of the present affidavit.
3. That the accompanying reply has been drafted and filed under my instructions, the contents thereof are true and correct based on the record maintained during the ordinary course of business of CPCB and available

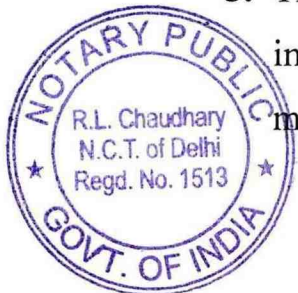

records and documents and the contents of the same are read over and explained to me and are not repeated herein for the sake of brevity.

*Rms*

**DEPONENT**  
**रुना उषा / Runa Oraon**  
**वैज्ञानिक 'ई' / Scientist 'E'**  
**केन्द्रीय प्रदूषण नियंत्रण बोर्ड**  
**Central Pollution Control Board**  
 (पर्यावरण, वन एवं जलवायु परिवर्तन मंत्रालय, भारत सरकार)  
 (M/o Environment, Forest & Climate Change, Govt. of India)  
 परिवेश भवन, पूर्वी अर्जुन नगर, दिल्ली-110032  
 Parivesh Bhawan, East Arjun Nagar, Delhi-110032

**VERIFICATION**

Verified at Delhi on this day of 12 MAY 2026, that the contents above are correct and true based on the records of the case as mentioned in the day-to-day affairs of the CPCB. Nothing has been concealed therefrom or misstated.

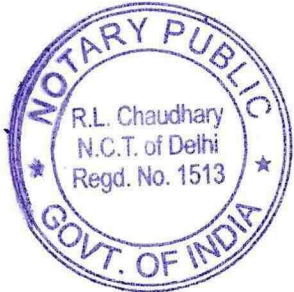

**ATTESTED**  
*Rms*  
**NOTARY PUBLIC**  
**GOVT. OF INDIA**

12 MAY 2026

12 MAY 2026

*Rms*

**DEPONENT**  
**रुना उषा / Runa Oraon**  
**वैज्ञानिक 'ई' / Scientist 'E'**  
**केन्द्रीय प्रदूषण नियंत्रण बोर्ड**  
**Central Pollution Control Board**  
 (पर्यावरण, वन एवं जलवायु परिवर्तन मंत्रालय, भारत सरकार)  
 (M/o Environment, Forest & Climate Change, Govt. of India)  
 परिवेश भवन, पूर्वी अर्जुन नगर, दिल्ली-110032  
 Parivesh Bhawan, East Arjun Nagar, Delhi-110032

Speed Post

F.No.B-31011/BMW {6.7 -III}/2016/HWMD/

23379-28421

February 20, 2017

To

(DGAFMS, SPCBs/PCCs and CBWTF Association)

**Sub: Revised Guidelines for Common Bio-medical Waste Treatment Facilities- reg.**

Sir,

This is to inform that the existing guidelines for Common Bio-medical Waste Treatment Facilities (CBWTFs) issued in the year 2003 has been reviewed in consultation with the concerned stakeholders by the Central Pollution Control Board and same has been revised in line with the Bio-medical Waste Management Rules, 2016 notified by the Ministry of Environment, Forest and Climate Change (MoEF & CC) under the Environment (Protection) Act, 1986.

Presently, these revised guidelines entitled "Revised Guidelines for Common Bio-medical Waste Treatment Facilities" are updated in CPCB Website at [http://cpcb.nic.in/wast/bioimedicalwast/Common\\_Bio\\_Medical\\_Waste\\_treatment\\_facilities.pdf](http://cpcb.nic.in/wast/bioimedicalwast/Common_Bio_Medical_Waste_treatment_facilities.pdf).

It is therefore requested that your organization may kindly initiate actions for ensuring compliance to the afore-said finalised guidelines and action taken report may please be submitted to CPCB periodically to apprise the MoEF & CC accordingly.

Yours faithfully,

(B. Vinod Babu)

Nodal Officer,

Waste Management Division

Copy to:

- (i) PS to 'CCB', CPCB : For kind information of 'CCB' please  
(ii) PS to 'MS', CPCB : For kind information of 'MS' please

केन्द्रीय प्रदूषण नियंत्रण बोर्ड

निर्गत.....

दिनांक.....

(B. Vinod Babu)



1473

केन्द्रीय प्रदूषण नियंत्रण बोर्ड  
CENTRAL POLLUTION CONTROL BOARD  
पर्यावरण, वन एवं जलवायु परिवर्तन मंत्रालय, भारत सरकार.  
MINISTRY OF ENVIRONMENT, FOREST & CLIMATE CHANGE, GOVT. OF INDIA.

## Annexure- II

By Speed Post

F.No. B-31011/BMW (6.7(IIIA)/4507)/2023/WM-I

April 16, 2025

To,

The Member Secretary,  
(All SPCBs/PCCs)

Subject: Revised guidelines for Common Biomedical Waste Treatment and Disposal Facilities - reg.

Sir/Madam,

This has reference to guidelines for Common Biomedical Waste Treatment and Disposal Facilities prepared by CPCB on 21.12.2016. In this regard, it is to inform that CPCB has reviewed and revised the guidelines for Common Biomedical Waste Treatment and Disposal Facilities. The said guidelines as revised by CPCB is available at following link:

<https://cpcb.nic.in/openpdffile.php?id=TGF0ZXN0RmlsZS80NDhfMTc0NDgwMDgzMI9tZWRpYXBob3RvMTA1MjUucGRm>

It is requested to kindly ensure implementation of the said guidelines.

Yours faithfully,

(V. P. Yadav)

Director &amp; Head

Waste Management Division -I

‘परिवेश भवन’ पूर्वी अर्जुन नगर, दिल्ली - 110032.

Parivesh Bhawan, East Arjun Nagar, Delhi - 110 032.

दूरभाष /Tel : 43102030, 22305792, वेबसाइट/Website: www.cpcb.nic.in

---

## Revised Guidelines for Common Bio-medical Waste Treatment and Disposal Facilities



### **CENTRAL POLLUTION CONTROL BOARD**

(Ministry of Environment, Forest and Climate Change)

Parivesh Bhawan, East Arjun Nagar

**DELHI -110 032**

website: [www.cpcb.nic.in](http://www.cpcb.nic.in)

**(December 21, 2016)**

---

### Abbreviations

APCD	-	Air Pollution Control Device
BMWM Rules	-	Bio-medical Waste Management Rules
CBWTF	-	Common Bio-medical Waste Treatment and Disposal Facility
CO	-	Carbon Monoxide
CO <sub>2</sub>	-	Carbon Dioxide
CPCB	-	Central Pollution Control Board
CRZ	-	Coastal Regulation Zone
DG	-	Diesel Generator
EC	-	Environmental Clearance
EIA	-	Environment Impact Assessment
ETP	-	Effluent Treatment Plant
GPS	-	Global Positioning System
HCFs	-	Health Care Facilities
HCl	-	Hydrochloric Acid
HOWM & TM Rules	-	Hazardous and Other Waste (Management & Transboundary Movement) Rules, 2016
MHz	-	Mega Hertz
MoEF& CC	-	Ministry of Environment, Forest & Climate Change
KM	-	Kilometer
KW	-	Kilowatt
MoU	-	Memorandum of Understanding
NABL	-	National Accreditation Board for Testing and Laboratories
NO <sub>x</sub>	-	Oxides of Nitrogen
O <sub>2</sub>	-	Oxygen
PCC	-	Pollution Control Committee
PLC	-	Programmable Logical Control
SEIAA	-	State Environment Impact Assessment Authority
SLF	-	Secured Landfill
SPCB	-	State Pollution Control Board
TSDF	-	Treatment Storage and Disposal Facility
TOC	-	Total Organic Carbon
VOCs	-	Volatile Organic Compounds

## CONTENT

S. No	Description	Page No.
1	Introduction	01
2	Criteria for development of a new Common Bio-medical Waste Treatment and Disposal Facility	02
3	Duties of the operator of a common bio-medical waste treatment and disposal facility	06
4	Applicability of the guidelines	06
5	Environmental laws applicable for commissioning or operation of a CBWTF	07
6	Location criteria	08
7	Land requirement	09
8	Coverage area of CBWTF	10
9	Treatment equipment	10
10	Infrastructure set up	15
11	Record keeping	20
12	Collection and transportation of bio-medical waste	25
13	Disposal option of solid waste generated from CBWTF	27
14	Cost to be charged by the CBWTF operator for the Health Care Facilities	29
15	Check list for development of CBWTF	29
16	Periodic inspection/monitoring or performance evaluation of the CBWTFs	30
	<b>List of Figure and Table</b>	
	<b>Figure 1.</b> Criteria for development of a CBWTF in a coverage area	05
	<b>Table 1:</b> Suggested validation test for treatment of bio-medical waste by autoclave/microwave/chemical treatment/dry heat sterilization	24
	<b>Table 2:</b> Suggested disposal option of solid waste generated from CBWTF	28
	<b>List of Annexure</b>	
	<b>Annexure-I:</b> Coverage area-wise gap analysis for assessing additional BMW treatment capacity requirement	31
	<b>Annexure -II:</b> Format for maintaining the record by the CBWTF Operator along with the transportation vehicle used for collection of the Bio-medical waste from the member HCFs	32
	<b>Annexure -III:</b> Log Book for operating the Incinerator/Plasma Pyrolysis and Autoclave	33
	<b>Annexure -IV:</b> Check list for Development of a CBWTF	34
	<b>Annexure -V:</b> Check list for Performance Evaluation of the CBWTF	38
	<b>Annexure -VI:</b> Stationary Source Emission Monitoring for Dioxins and Furans	50
	<b>References</b>	53

---

## 1) Introduction

A Common Bio-medical Waste Treatment and Disposal Facility (CBWTF) is a set up where biomedical waste generated from member health care facilities is imparted necessary *treatment* to reduce adverse effects that this waste may pose on human health and environment. The treated recyclable waste may finally be sent for disposal in a secured landfill or for recycling.

According to the Bio-medical Waste Management Rules, 2016, "*bio-medical waste treatment and disposal facility*" means any facility wherein treatment, disposal of bio-medical waste or processes incidental to such treatment and disposal is carried out, and includes common bio-medical waste treatment facilities and "*operator of a common bio-medical waste treatment facility*" means a person who owns or controls a Common Bio-medical Waste Treatment and Disposal Facility (CBWTF) for the collection, reception, storage, transport, treatment, disposal or any other form of handling of bio-medical waste.

The Bio-medical Waste Management Rules, 2016 (hereafter referred as BMWM Rules) restricts occupier for establishment of on-site or captive bio-medical waste treatment and disposal facility, if a service of common bio- medical waste treatment and disposal facility is available within a distance of seventy-five kilometer, as installation of individual treatment facility by health care facility (HCF) requires comparatively high capital investment. In addition, it requires separate dedicated and trained skilled manpower and infrastructure development for proper operation and maintenance of treatment systems. The concept of *CBWTF* is not only addresses such problems but also prevents proliferation of treatment technologies in a particular town or city. In turn, it reduces the monitoring pressure on regulatory agencies. By running the treatment equipment at CBWTF to its full capacity, the cost of treatment of per kilogram bio-medical waste gets significantly reduced. Its considerable advantages have made CBWTF popular and proven concept in most part of the world.

The CBWTFs are also required to set up based on the need for ensuring environmentally sound management of bio-medical waste keeping in view the techno-economic feasibility and viable operation of the facility with minimal impact on human health and environment.

Since 1998, the CBWTF as an option for treatment of bio-medical waste also been legally introduced in India. Considering the likely impacts that may cause to the patients undergoing treatment because of operation of the captive treatment

---

equipment within the health care facilities (HCFs), now the Bio-medical Waste Management Rules, 2016 restricts the Occupier (i.e., HCF) for ensuring treatment and disposal of generated bio-medical waste through a CBWTF, located within a distance of 75 KM. Further, these rules eased the bottleneck in upbringing the CBWTF by making department in the business allocation of land assignment in the State or UT administration responsible for providing a suitable site (s) within its jurisdiction.

The concept of CBWTF is also being widely accepted in India among the healthcare units, medical associations and entrepreneurs. In order to set up a CBWTF to its maximum perfection, care shall be taken in choosing the right technology, development of CBWTF area, proper designing of transportation system to achieve optimum results etc. Key features of CBWTF have been addressed in the subsequent sections.

To facilitate the treatment and disposal of bio-medical waste generated from the HCFs, at present (as per Annual Report 2014 submitted by the SPCBs/PCCs), there are 192 no. of CBWTFs in operation and 33 no. of CBWTFs are under construction. Also, the Bio-medical Waste Management Rules, 2016 mandates that the operator of a CBWTF authorised by the prescribed authority is required to take all necessary steps to ensure that the bio-medical waste collected from the occupier is transported, handled, stored, treated and disposed of, without any adverse effect to the human health and the environment, in accordance with the BMWM Rules and the guidelines issued by the Central Government or the Central Pollution Control Board (CPCB) from time to time. Therefore, these guidelines have been prepared with an aim to have uniformity in ensuring site selection, allowing and establishment of a state-of-the-art CBWTF, operation as well as verification of compliance to the BMWM Rules, 2016 throughout the country. However, any other aspects which are not been covered under these guidelines and needs attention, in such a case, the prescribed authority may take suitable action in the interest of protection of the environment in consultation with MoEF & CC/CPCB. Also, it is pertinent to mention here that these guidelines are mandatory henceforth under the Bio-medical Waste Management Rules, 2016

**2) Criteria for development of a new Common Bio-medical Waste Treatment and Disposal Facility for a locality or region.**

Prior to allowing any new CBWTF, following criteria or steps may be followed:

- a) Prescribed authority under the BMWM Rules, 2016 [i.e., State Pollution Control Board (SPCB) in the respective State or Pollution Control Committee (PCC) in the respective

---

Union Territory Administration] is required to prepare an inventory or review with regard to the bio-medical waste generation at least once in five years in the coverage areas of the existing bio-medical waste treatment and disposal facility. The prescribed authority is also required to extrapolate the coverage-area wise bio-medical waste generation for the next ten years.

- b) SPCB/PCC is required to conduct gap analysis w.r.to coverage area of the bio-medical waste generation and also projected over a period of next ten years, adequacy of existing treatment capacity of the CBWTF in each coverage area of radius 75 KM, as given in **Annexure-I**.

All the SPCBs and PCCs shall conduct the gap analysis and based on the gap analysis, action plan for development of new CBWTFs is required to be prepared and submitted to MoEF & CC & CPCB within six months' time. In case of States/UTs, where no CBWTF is available, in such a case, SPCB/PCC being prescribed authority under the BMWM Rules is required to submit the detailed proposal to MoEF & CC/MoH & FW through the respective State Government or UT Administration. Also, the option of forming association by the group of health care facilities (HCFs) to develop their own CBWTF also be encouraged following these guideline. In case, any coverage area requires additional treatment capacity , in such a case, action may be initiated by the prescribed authority for allowing a new CBWTF in that locality without interfering the coverage area of the existing CBWTF and beds covered by the existing CBWTF.

- c) SPCB/PCC shall identify the coverage area, which require additional treatment facility and bring it to the notice of the concerned department in the business allocation of land assignment in the respective State Government or UT Administration. The department in the business allocation of land assignment shall be responsible for providing suitable site in the identified coverage area for setting up of a CBWTF, in consultation with the prescribed authority (i.e., SPCB/PCC), other stakeholders and in accordance with these guidelines issued by CPCB from time to time.
- d) Alternately, a CBWTF may also be allowed to be established on a land procured by an entrepreneur in accordance with the location criteria suggested under these guidelines.
- e) The SPCB/PCC or concerned department in the business allocation of land assignment in the respective State Government or UT Administration may seek expression of interest from the proponents for development of new CBWTF (s) in the identified coverage area. Upon allocation of site to the proponent, the proponent is
-

---

required to take necessary approvals as required under the Environment (Protection) Act, 1986 for development of the new CBWTF in accordance with these guidelines.

- f) In the absence of expression of interest by any proponent, then SPCB/PCC shall insist health care facilities to form association and to develop its own CBWTF in line with these guidelines or to have captive treatment facilities for ensuring treatment and disposal of generated bio-medical waste as stipulated under the BMW Rules, 2016.
- g) In case of any regulatory action including closure of any existing CBWTF is inevitable, the respective SPCB/PCC may take action under the BMW Rules including for making alternate arrangement to ensure safe disposal of the bio-medical waste generated from the member health care facilities of such default CBWTF through CBWTF located nearby.
- h) In case of hilly areas considering the geography, only one CBWTF with adequate treatment capacity may be developed covering atleast two districts to cater treatment services to the HCFs located in the respective Districts. The selection and allocation of site etc., should be done as per the criteria suggested under these guidelines. The treatment charges to be prescribed by the respective SPCB/PCC in consultation with the State Advisory Committee.

The criteria for development of CBWTFs in any coverage area is also depicted in **Figure 1**.

---

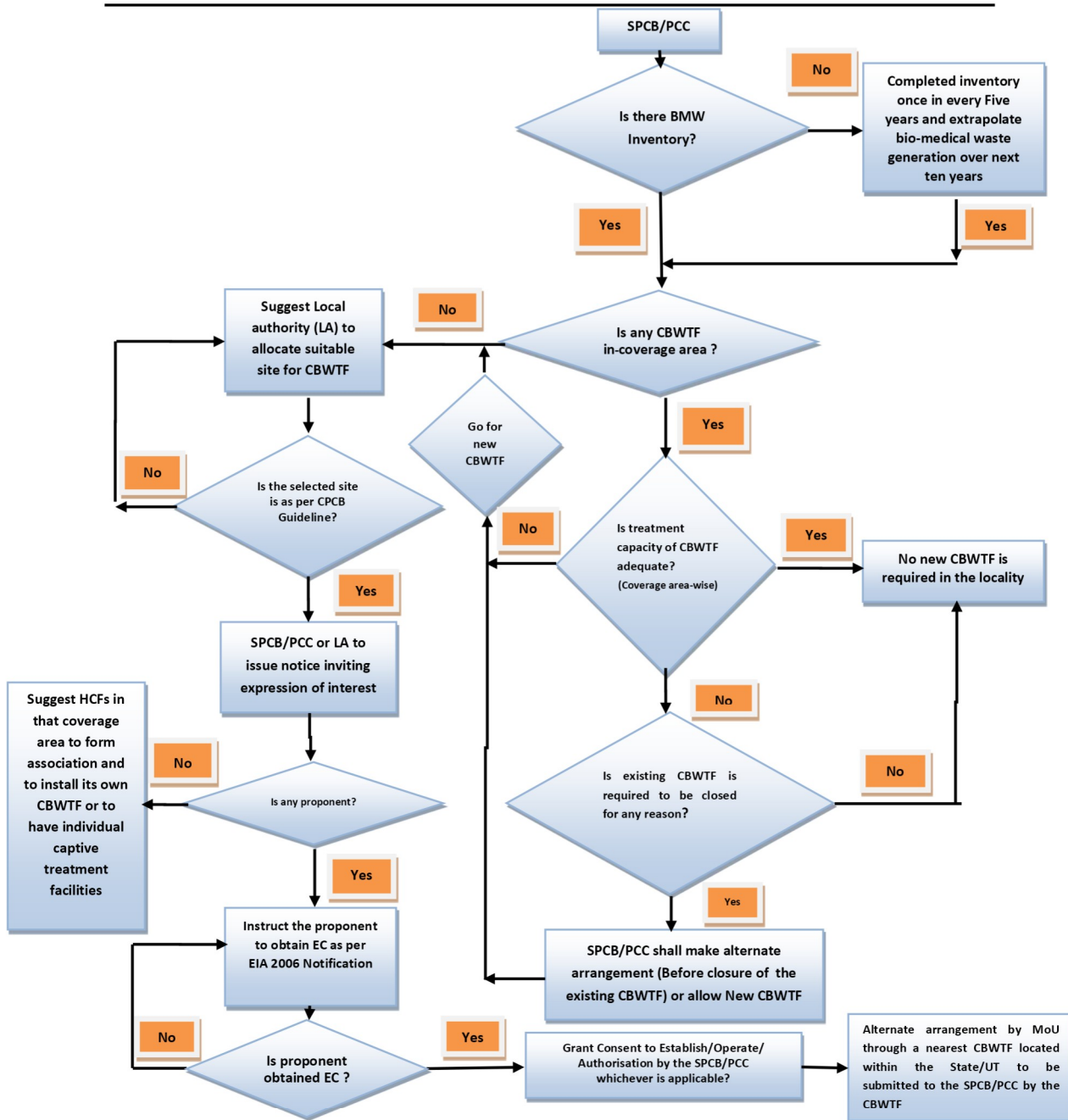

**Figure 1. Criteria for Development of a CBWTF in a coverage area**

### 3) **Duties of the operator of a common bio-medical waste treatment and disposal facility**

The duties of the operator of a common bio-medical waste treatment and disposal facility (CBWTF) as enunciated under Rule 5 of the Bio-medical Waste Management Rules, 2016 shall be ensured and complied with. Also, all the existing CBWTFs shall also complete augmentation of the existing incineration facility so as to comply w.r.to the residence time as well as emission norms including for Dioxins and Furans prescribed under BMWM Rules, 2016 within two years from the date of notification of the BMWM Rules, 2016 (i.e., prior to 27.03.2018). In addition to the above, to ensure proper management of bio-medical waste in the respective coverage area, as a mitigation measure, especially in the event of

- (a) a temporary break down (not more than a week) of a CBWTF especially for rectification of the refractory lining of the incineration chambers or change of requisite APCD due to failure; and
- (b) Closure of a CBWTF for violation of the provisions of the BMWM Rules or any other reason.

Prior to commencement of a new CBWTF as well as all the existing CBWTF Operators are required to submit action plan, to the respective SPCB/PCC, for imposing suitable condition while granting authorisation under the BMWM Rules, 2016. The action plan should also include:

- (a) a MoU made with the nearest CBWTF located within the respective State/UT, as alternate arrangement. In case, if there is no CBWTF located nearby then such CBWTF should have to install stand by treatment equipment (equal to the existing treatment capacity as per consents granted by the SPCB/PCC), and
- (b) decontamination plan of the CBWTF for execution of such plan prior to closure of a CBWTF.

### 4) **Applicability of these guidelines**

These guidelines are applicable to all the upcoming or new CBWTFs. In case of the existing CBWTFs, these guidelines shall be applicable in case

- (a) the existing CBWTFs desires to expand or enhance the existing treatment capacity
- (or)**
- (b) the existing CBWTFs desires to modernize the existing treatment equipment with the new equipment with enhancement in the existing treatment capacity.

---

**5) Environmental laws applicable for commissioning or operation of a CBWTF**

Operation of a CBWTF leads to air emissions as well as waste water generation as in case of an industrial operation. Most common sources of waste water generation in CBWTFs are vehicle washing, floor washing, and scrubbed liquid effluent from air pollution control systems attached with the incinerator/plasma pyrolysis. Incineration as well as DG Set is the general source of air emissions.

**5.1** Any other approvals (such as Land Use /Change in Land Use as applicable) required from the concerned authorities under various laws have to be complied with by the proponent of the CBWTF prior to development of a CBWTF-

**5.2 Consents under Water (Prevention and Control of Pollution) Act, 1974 and Air (Prevention and Control of Pollution) Act, 1981 as well as Authorization under the BMWM Rules, 2016**

The project proponent of the CBWTF is required to obtain 'Consent to Establishment' under Rule 25 of the Water (Prevention and Control of Pollution) Act, 1974 and under Rule 21 of the Air (Prevention and Control of Pollution) Act, 1981, from the respective prescribed authority i.e. SPCB/PCC. Upon installation of the requisite equipment, the CBWTF Operator is also required to obtain authorization under BMWM Rules, 2016 co-terminus with consent to operate under Water (Prevention and Control of Pollution) Act, 1976 & Air (Prevention and Control of Pollution) Act, 1981 from the respective SPCB/PCC prior to commencement of the CBWTF.

**5.3 Environmental Clearance under EIA Notification 2006**

Ministry of Environment, Forest & Climate Change (MoEF & CC), notified amendment to the EIA Notification 2006 and published vide MoEF & CC Notification of S.O. 1142 (E) dated April 17, 2015. According to this notification, the 'bio-medical waste treatment facility' is categorized under the Item 7 (da) in the schedule, requiring 'environmental clearance' from the State Environment Impact Assessment Authority (SEIAA). Therefore, the CBWTF operator is also required to obtain 'Environmental Clearance (EC)' from the respective SEIAA or Ministry of Environment, Forest& Climate Change (MoEF& CC), as the case may be, before any construction work, or preparation of land by the projects management, which include the following:

- a) All new projects or activities pertaining to the bio-medical waste treatment facility; and
  - b) Expansion and modernization with additional treatment capacity of existing bio-medical waste treatment facility (excluding augmentation of incineration facility)
-

for compliance to the residence time as well as Dioxins and Furans without enhancing the existing treatment capacity).

- c) Any expansion or modification in the treatment capacity or relocation of the existing CBWTF (requires compliance to the relevant provisions notified under the Environment (Protection) Act, 1986 by the MoEF & CC

#### 6) Location criteria

In the context of these guidelines, buffer zone represents a separation distance between the source of pollution in CBWTF and the receptor - following the principle that the degree of impact reduces with increased distance. The following parameters may be considered for ascertaining buffer distance on case-to-case basis:

- (i) potential for spread of infection from wastes stored in the premises.
- (ii) applicable standards for pollution control and the relative efficiency of the existing incinerators and emission control systems,
- (iii) potential of fugitive dust emission from incinerators,
- (iv) potential for discharge of wastewater
- (v) the potential for odour production,
- (vi) the potential for noise pollution,
- (vii) the risk posed to human health and safety due to exposure to emissions from incinerator,
- (viii) the risk of fire and
- (ix) Significance of the residual impacts such as bottom ash and fly ash.

As far as possible, the CBWTF shall be located near to its area of operation in order to minimize the transportation distance in waste collection, thus enhancing its operational flexibility as well as for ensuring compliance to the time limit for treatment and disposal of bio-medical waste as stipulated under the BMWM Rules (i.e., within 48 hours). Also, the location of the CBWTF should be in conformity to the CRZ Norms and other provisions notified under the Environment (Protection) Act, 1986. The location shall be decided in consultation with the State Pollution Control Board (SPCB)/ Pollution Control Committee (PCC). The location criteria for development of a CBWTF are as follows:

- (a) A CBWTF shall preferably be developed in a notified industrial area without any requirement of buffer zone **(or)**
- (b) A CBWTF can be located at a place reasonably far away from notified residential and sensitive areas and should have a buffer distance of preferably 500 m so that it shall

have minimal impact on these areas. In case of non-availability of such a land, the buffer zone distance from the notified residential area may be reduced to less than 500 m by SPCB/PCC without referring the matter to CPCB by prescribing additional control measures such as (i) adoption of best available technologies (BAT) by the proponent of CBWTF; (ii) prescribing stringent standards for operation of the CBWTF by the SPCB/PCC; (iii) adoption of zero liquid discharge by the CBWTF and (iv) in case of any complaints from the public, then CBWTF should prove that the facility is not causing any adverse impact on environment and habitation in the vicinity. If SPCB/PCC is not in a position to resolve the issue relating to buffer zone while selecting the site for CBWTFs, in such a case, SPCBs/PCCs may refer the matter to CPCB.

- (c) The CBWTF can also be developed as an integral part of the Hazardous Waste Treatment Storage and Disposal Facility (TSDF) subject to obtaining of necessary approvals from the authorities concerned including 'environmental clearance' as per Environmental Impact Assessment 2006 and further amendments notified under the Environment (Protection) Act, 1986, provided there is no CBWTF exist within 150 KM distance from the existing TSDF.

## 7) Land requirement

Sufficient land shall be allocated to the CBWTF to provide all requisite systems which include dedicated space for storage of waste (both treated and untreated), waste treatment equipment, vehicle washing bay, vehicle parking space, ETP, incineration ash storage provision, administrative room, space for DG Set etc.,.

- (a) Preferably, a CBWTF shall be set up on a plot size of not less than one acre in all the areas. However, a CBWTF can be developed in adjacent plots but cannot be set up in two or more different plots located in different areas. Separate plots can be permitted only for vehicle parking if located in the close vicinity of the proposed CBWTFs or the existing CBWTFs.
- (b) In case of upcoming or new CBWTFs (both in municipal limits with population more than 25 lakhs or in rural areas), the land area requirement may be relaxed (but in any case not less than 0.5 acre) by the SPCB/PCC, with additional control measures such as zero liquid discharge, increase in stack height, stringent emission norms, odour control measures or any other measures felt necessary by the prescribed authority on case-to-case basis, only in consultation with CPCB.

---

**8) Coverage area of CBWTF**

Suggested coverage area for development of a CBWTF is as follows:

- a) A CBWTF located within the respective State/UT shall be allowed to cater healthcare units situated at a radial distance of 75 KM. However, in a coverage area where 10,000 beds are not available within a radial distance of 75 KM, existing CBWTF in the locality (located within the respective State/UT) may be allowed to cater the healthcare units situated upto 150 KM radius w.r.to its location provided the bio-medical waste generated is collected, treated and disposed of within 48 hours as stipulated under the BMWM Rules.
- b) In case, number of beds is exceeding >10,000 beds in a locality (i.e. coverage area of the CBWTF under reference) and the existing treatment capacity is not adequate, in such a case, a new CBWTF may be allowed in such a locality in compliance to various provisions notified under the Environment (Protection) Act, 1986, to cater services only to such additional bed strength of the HCFs located.
- c) In case of hilly areas, considering the geography, only one CBWTF with adequate treatment capacity may be developed covering atleast two districts to cater treatment services to the HCFs located in the respective Districts. The selection and allocation of site etc. should be done as per the criteria suggested under these guidelines. The treatment charges to be prescribed by the respective SPCB/PCC in consultation with the State Advisory Committee to be constituted under the BMWM Rules by the respective State Government or UT Administration.

**9) Treatment equipment**

The Common Bio-medical Waste Treatment Facility should treat the bio-medical waste as per BMWM Rules and as per the authorisation granted by the prescribed authority. The CBWTF should have the following treatment facilities:

**a) *Incineration/Plasma Pyrolysis***

***Incineration*** is a controlled combustion process where waste is completely oxidized and harmful microorganisms present in it are destroyed/ denatured under high temperature. The guidelines for "Design & Construction Requirements of Bio-medical Waste Incinerators" by CPCB from time to time shall be followed for selecting/or augmenting the incinerator.

---

---

**Plasma Pyrolysis** is an alternate to incinerator, Plasma Pyrolysis treatment technology can be installed for disposal of bio-medical waste categories as per BMWM Rules wherein destruction of bio-medical waste is similar to incineration can be achieved. In case of plasma pyrolysis, waste is treated at high temperature under controlled condition to form gases like methane, hydrogen and carbon monoxide which are subjected to combustion (oxidation) in secondary chamber. In the plasma pyrolysis process waste is converted into small clinker which can be disposed in secured landfills.

**b) Autoclaving/Hydroclaving**

**(i) Autoclaving** is a low-heat thermal process where steam is brought into direct contact with waste in a controlled manner and for sufficient duration to disinfect the wastes as stipulated under the Bio-medical Waste Management Rules. For ease and safety in operation, the system should be horizontal type and exclusively designed for treatment of bio-medical waste. For optimum results, pre-vacuum based system be preferred against the gravity type system. It shall have tamper-proof control panel with efficient display and recording devices for recording critical parameters such as time, temperature, pressure, date and batch number etc. as required under the BMWM Rules.

**(ii) Hydroclaving** is similar to that of autoclaving except that the waste is subjected to indirect heating by applying steam in the outer jacket. The waste is continuously tumbled in the chamber during the process.

**c) Microwaving:** In microwaving, microbial inactivation occurs as a result of the thermal effect of electromagnetic radiation spectrum lying between the frequencies 300 and 300,000MHz. Microwave heating is an inter-molecular heating process. The heating occurs inside the waste material in the presence of steam.

**d) Chemical disinfection:** Though chemical disinfection or alternates as stipulated under the BMWM Rules is also an option for treatment of certain categories of bio-medical waste such as glass waste but looking at the volume of waste to be disinfected at the CBWTF and the pollution load associated with the use of chemical disinfectants, the chemical disinfection for treatment of bio-medical waste as part of a CBWTF may be used sparingly or avoided as far as possible.

**e) Dry heat sterilization:** This is the additional option for treatment of waste sharps as stipulated under the BMWM Rules. In this method, waste sharps are treated using

---

---

dry heat (hot air) at a temperature not less than 185<sup>0</sup>C, at least for a residence period of 150 minutes in each cycle ( with sterilization period of 90 minutes).

**f) *Shredder:*** Shredding is a process by which waste are de-shaped or cut into smaller pieces so as to make the wastes unrecognizable. It helps in prevention of reuse of bio-medical waste and also acts as identifier that the wastes have been disinfected and are safe to dispose off. A shredder to be used for shredding bio-medical waste shall confirm to the following minimum requirements:

- (i) The shredder for bio-medical waste shall be of robust design with minimum maintenance requirement;
  - (ii) The shredder should be properly designed and covered to avoid spillage and dust generation. It should be designed such that it has minimum manual handling;
  - (iii) The hopper and cutting chamber of the shredder should be so designed to accommodate the waste bag full of bio-medical waste;
  - (iv) The shredder blade should be highly resistant and should be able to shred waste sharps, syringes, scalpels, blades, plastics, catheters, intravenous sets/ bottles, blood bags, gloves, bandages etc. It should be able to handle/ shred wet waste, especially after microwave/ autoclave/hydroclave;
  - (v) The shredder blade shall be of non-corrosive and hardened steel;
  - (vi) The shredder should be so designed and mounted so as not to generate dust, high noise & vibration;
  - (vii) If hopper lid or door of collection box is opened, the shredder should stop automatically for safety of operator;
  - (viii) ]In case of shock-loading (non-shreddable material in the hopper), there should be a mechanism to automatically stop the shredder to avoid any emergency/accident;
  - (ix) In case of overload or jamming, the shredder should have mechanism of reverse motion of shaft to avoid any emergency/accident;
  - (x) The motor shall be connected to the shredder shaft through a gear mechanism, to ensure low rpm and safety;
  - (xi) The unit shall be suitably designed for operator safety, mechanical as well as electrical;
  - (xii) The shredder should have low rotational speed (maximum 50 rpm). This will ensure better gripping and cutting of the bio-medical waste;
-

- (xiii) The discharge height (from discharge point to ground level) shall be sufficient (minimum 3 feet) to accommodate the containers for collection of shredded material. This would avoid spillage of shredded material;
- (xiv) The minimum capacity of the motor attached with the shredder shall be 3 KW for 50 Kg/hr, 5 KW for 100 kg/hr & 7.5 KW for 200 Kg/hr and shall be three phase induction motor. This will ensure efficient cutting of the bio-medical wastes as prescribed in the Bio-medical Waste Management Rules; and
- (xv) The shredder also should be fitted with separate 'energy meter' for recording total energy consumed for operation of this equipment.

**g) *Sharp pit/ Encapsulation:*** A sharp pit or a facility for sharp encapsulation in a metal container or cement concrete shall be provided for treated sharps (*i.e., treatment by autoclaving or dry heat sterilization followed by shredding or mutilation*). An option may also be worked out for recovery of metal from treated and shredded waste sharps within the CBWTF or iron foundries having consent to operate from the SPCBs/PCCs and located nearby, as per the conditions imposed in authorization granted under BMWM Rules by the SPCB/PCC.

A sharp pit may be of circular or rectangular shape and shall be dug and lined with cement plastered brick masonry or concrete rings. The pit should be covered with a heavy concrete slab with a provision of galvanized steel pipe projecting about 1.5 meters above the slab, with an internal diameter of up to 50 mm or 1.5 times the length of vials, whichever is more. The top opening of the steel pipe shall have a provision of locking after the treated waste sharps are disposed into the sharp pit. When the pit is full, it can be sealed completely, after another pit is prepared. In case of high water table regions (*i.e., where water table is less than 6 metres beneath the bottom of the sharp pit*), a tank with above mentioned arrangements shall be made above the ground.

**h) *Deep burial:*** Any SPCB/PCC should not allow the 'deep burial' of bio-medical waste as a part of CBWTF. Any existing CBWTF having disposal of bio-medical waste by deep burial should have the requisite treatment equipment as stipulated under the BMWM Rules, *within six months* from the date of finalization of these guidelines.

**i) *Non-burn technology:*** Non-incineration technologies for disposal of bio-medical waste are adopted in some of the developed countries. Non-incineration technology comprises of shredding and disinfection by autoclaving/microwaving or chemical treatment. The treated waste can be disposed along with municipal solid waste in sanitary landfills or through waste to energy plants. Such option can also be adopted in places where the sanitary landfill or waste to energy plant for disposal of municipal

solid waste is available. Such technology is permitted only after prior approval of MoEF & CC and only after obtaining authorization under the BMW Rules from the respective SPCB/PCC for the purpose of carrying out trial runs for assessment of efficacy of the treatment equipment.

- j) *Vehicle/Containers washing facility:*** Every time a vehicle is unloaded, the vehicle and empty waste containers shall be washed properly and disinfected. Washing can be carried out in an open area but on an impermeable surface and liquid effluent so generated shall be conveyed and treated in an effluent treatment plant. The impermeable area shall be of appropriate size so as to avoid spillage of liquid during washing.
- k) *Effluent Treatment Plant:*** A suitable Effluent Treatment Plant (ETP) shall be installed to ensure that liquid effluent generated during the process of washing containers, vehicles, floors etc. is treated and reused after treatment. Proper treatment of waste water shall be ensured in case of zero discharge by recirculation of treated waste water for scrubbing. *ETP may have treatment unit operations* comprising collection tank, O & G trap, chemical dosing cum mixing (Flash and slow), coagulation chamber, primary settling tank (s), biological treatment process, secondary settling tank, pressure filter and activated carbon filter, pH Correction tank (wherever recirculation of treated water is practiced) *so as to comply with the liquid discharge standards stipulated under the Bio-medical Waste Management Rules, 2016.* ETP may also have the following provisions:
- (i) separate 'energy meter' so as to know total consumption of electricity for operation of the machinery attached with the ETP.
  - (ii) pH meter so as to know pH level of treated water as well as pH level of treated water used for recirculated or recycling in APCD attached with the incinerator or any utility within the CBWTF.
  - (iii) A 'magnetic flow meter' should also be fitted at all the water supply extraction points of the CBWTF as well as the outlet to know the total wastewater treated for further end use or discharge in compliance to the BMW Rules.
  - (iv) Provision of 'press filter' to reduce the moisture content of the ETP Sludge or it may be dried in 'sludge drying bed'. After removal of moisture content or drying, same need to be disposed off in an environmentally sound manner depending upon the hazardous constituents present in it as per Hazardous and Other Waste (Management and Transboundary Movement) Rules, 2016.

In case, ETP sludge contains metal contents within the prescribed limits as per Hazardous & Other Waste (Management & Transboundary Movement) Rules, 2016, such ETP sludge shall be given to CBWTF for incineration or to hazardous waste treatment, storage and disposal facility (TSDF) for disposal in secured landfill.

**Note:**

- a) If any CBWTF desires to adopt any other technology other than referred under Schedule –I of the BMWM Rules, may adopt new technology only with the prior approval from MoEF & CC and is also required to obtain authorization under the BMWM Rules from the respective SPCB/PCC for carrying out trial run for assessment of efficacy of the new technology.
- b) All the treatment equipment should be operated and complied with the norms as stipulated under Schedule II of the Bio-medical Waste Management Rules, 2016 published by MoEF & CC vide GSR 343 (E) dated 28<sup>th</sup> March, 2016.
- c) Incinerator / Plasma Pyrolysis/ Autoclaving/Microwaving/ Hydroclaving/ Shredder/ Dry Heat Sterilization/ ETP should be fitted with separate 'energy meter' for recording total energy consumed for operation of these equipment.
- d) In the event of temporary shutdown (not more than a week) due to any operational problems in the treatment equipment (such as restoration of refractory lining or maintenance or repairs in APCD), to ensure bio-medical waste collected from the member health care facilities is treated within the time limit as stipulated under the BMWM Rules, each all the CBWTF operators should also be provided with stand by treatment equipment especially incinerator/plasma pyrolysis/autoclave (or) alternately MoU made with the nearby CBWTF (located within the State/UT) shall be submitted to the respective SPCB/PCC, by all the existing CBWTF operators (whereas the upcoming facilities have to make such arrangement prior to commencement of the facility) so as to include such condition while granting authorisation under the BMWM Rules, 2016 to the concerned CBWTF operators (vice-versa).

**(10) Infrastructure set up**

The CBWTF shall have enough space within it to install required treatment equipment, untreated and treated waste storage area, vehicle-parking, vehicle and containers washing area, Effluent Treatment Plant (ETP), administration room or staff room etc. The required area for CBWTF would depend upon the projected amount of bio-medical waste to be handled by it. A CBWTF shall have the following infrastructure:

**a) Treatment Equipment Room**

A separate housing may be provided for each treatment equipment at the CBWTF such as incinerator room, autoclave room, microwave room etc., as applicable. Each room shall have well-designed roof and walls. Such room shall be well ventilated and easy to wash. The floor and interior finishing of the room shall be such that chances of sticking/harboring of microorganisms are minimized. This can be attained by

---

providing smooth & fine floor and wall surfaces (to a height of 2 meter from floor) preferably of tiles. The number of joints in such surfaces shall be minimal. The equipment room shall also have a separate cabin, to supervise the operation of the equipment and to record the waste handling and equipment operational data attached to each equipment room. There shall be two waste storage rooms, one for storage of untreated waste and another for treated waste and may be located at a distance from each other. The storage room shall have provisions similar to that of equipment room being well-ventilated with easy to wash floors & walls, smooth and fine surfaces etc. All the treatment equipment rooms and waste storage rooms should be provided with 'fly catcher/killing device'. The room shall be washed and cleaned with a suitable disinfectant every day.

**b) Main waste storage space**

Separate space shall be provided near the entry point of the CBWTF to unload and store all biomedical wastes that have been transported to the CBWTF by its own transportation vehicle. The size of the room shall be adequate to store all wastes transported to the CBWTF. The front portion of the room shall be utilized for unloading the wastes from the vehicle and back or side portion shall be utilized for shifting the wastes to the respective treatment equipment. In the front portion of the room where transportation vehicle is parked for unloading, the floor shall be made impermeable so that any liquid spillage during unloading does not percolates into the ground. The liquid generated during handling of wastes and washing, shall be diverted to the inlet of effluent treatment plant (ETP). In the main storage room, wastes shall be stacked with clear distinction as per the color coding of the containers by providing partitions. From here, the colored containers may be sent to the respective treatment equipment by using suitable closed type of conveyance (trolley etc.,). The main storage room too shall have provisions similar to that of equipment room such as roofing, well ventilated, easy to wash floors & walls, smooth and fine surfaces etc.

Apart from the above, a CBWTF should have separate storage provision for storage of mercury bearing waste collected from the member health care facilities as per the procedure given in CPCB guidelines. Mercury storage provision should be provided as per the guidelines issued by CPCB (refer [www.cpcb.nic.in](http://www.cpcb.nic.in)). The capacity of the mercury storage provision should be maximum of 90 days and by which the collected mercury bearing waste shall have to be disposed of through a TSDF located nearby following the manifest as per Hazardous and Other Waste (Management and Transboundary Movement) Rules, 2016. The charges for collection and disposal of

---

---

mercury bearing waste shall be collected by the CBWTF from the respective member HCF.

**c) Treated waste storage room**

Separate space should be provided to store the wastes treated in different treatment units. The wastes shall be stored in separate group as per the disposal options. Other provisions in the room shall be similar to the main storage room. Waste such as incineration ash/vitrified ash generated in the process of incineration/plasma pyrolysis respectively shall be stored safely in a separate area under the shed so as to avoid entry of rain water during the monsoon and for easy collection. In case, incineration ash/ vitrified ash is found to be hazardous waste in nature same should be disposed of through any authorized TSDF operator located nearby following the manifest as per Hazardous and Other Waste (Management and Transboundary Movement) Rules, 2016. In case of a State/UT where TSDF is not available, all the CBWTF operators have to store incineration ash safely as per these guidelines.

**d) Administrative Room**

This room shall be utilized for general administration, record keeping, billing etc.

**e) Generator set**

CBWTF shall have a generator set of adequate capacity as standby arrangement for power, with sufficient capacity to run the treatment equipment during the failure of power supply. The generator set shall comply with the necessary requirement as per DG Set norms notified under the Environment (Protection) Act, 1986.

**f) Continuous emission monitoring system (CEMS)**

Monitoring provision for continuous monitoring of the incinerator/plasma pyrolysis stack emission shall be installed by the CBWTF operators for the parameters as stipulated by the respective SPCB/PCC as per the authorisation granted under the BMWM Rules, 2016. Other-wise, at present, all the existing CBWTF operators are required to carry out stack emission monitored using continuous emission monitoring system for the flue gas parameters such as CO<sub>2</sub>, O<sub>2</sub>, CO as well as primary & secondary chamber temperatures, and records maintained. The continuous emission monitoring system for stack emission should be installed as per the guidelines issued by SPCB/PCC/CPCB. Also, the real time continuous stack emission

---

---

monitoring data is also required to be transmitted to the servers of the respective SPCB/PCC as well as CPCB, by all the existing CBWTF operators

**g) Vehicle Parking**

Provision for parking shall be made within the confines of the site for parking of required number of vehicles, loading and unloading of the vehicles meant for transporting waste to and from the facility, etc.. In case of a CBWTF with space constraints, multi-storey parking or a separate provision may be allowed only for parking of vehicles.

**h) Display and sign board**

An identification board (Display) of durable material and finish shall be displayed at the entrance to the facility. This shall clearly display the name of the facility, owner name, address and telephone number of the operator and the prescribed authority, no. of hours of operation & operational hours, telephone numbers of the personnel to be contacted in the event of an emergency, validity period of authorization as well as total daily waste treated and disposed. Also, sign boards should be provided at all the salient points (untreated waste storage area, treatment equipment, treated waste storage area, ETP, firefighting equipment) within the facility.

**i) Washing Room**

A washing room shall be provided for eye washing/hand washing/ bathing etc. for the workers.

**j) Site Security**

High walls, fencing and guarded gates shall be provided at the facility to prevent unauthorized access to the site by humans and livestock.

**k) Fire safety**

Fire safety equipment such as sand buckets and fire extinguishers should be provided at all the salient points of the CBWTF including at the diesel storage areas, diesel tanks connected with the incinerator etc. Fire alarm also should be provided within the CBWTF to prompt the workers in the event of any fire hazard. Workers should also be trained in First Aid administration.

---

---

**l) First Aid Box**

First Aid Box with necessary provisions need to be provided at all the salient points within the facility.

**m) Green Belt**

The open area available within the CBWTF shall be developed into green belt.

**n) Website: ( newly added as per BMWM Rules, 2016)**

All the existing CBWTFs shall develop own website by 27.03.2017 whereas the upcoming CBWTF shall develop the website prior to the commencement of the facility. The website should be uploaded with relevant information periodically (on monthly basis) especially as detailed below:

- (i) A copy of the Environmental Clearance obtained;
  - (ii) Copies of the Consents under the Water (Prevention and Control of Pollution) Act, 1974 and Air (Prevention and Control of Pollution) Act, 1981 as well as the Authorisation under the BMWM Rules obtained from the SPCB/PCC;
  - (iii) List of all the member Health Care Facilities with complete address, bedded or non-bedded HCFs, no. of beds, bar code, category-wise average bio-medical waste generation in kg/annum;
  - (iv) Charges levied on the member Health Care Facilities (HCFs) for treatment and disposal of bio-medical waste;
  - (v) Vehicles connected with a provision of GPS as per BMWM Rules and Vehicle-wise route chart for collection, transportation of bio-medical waste from the member HCFs;
  - (vi) Real time continuous online stack emission monitoring data;
  - (vii) Daily bio-medical waste collected, received and treated ( Member HCF-wise);
  - (viii) Monthly details of total waste collected from the member HCFs, total waste treated, and treated recyclable plastic waste or glass waste sold to the parties and final mode of disposal of incineration ash;
  - (ix) A copy of the annual report submitted to the respective SPCB/PCC;
  - (x) Monitoring results of the stack emissions, treated wastewater and incineration ash, as per the frequency stipulated under the BMWM Rules;
  - (xi) List of HCFs ( located within the coverage area) with complete address which have not taken membership of the CBWTF for disposal of Bio-medical waste;
  - (xii) Contact person, contact telephone number and e-mail addresses of the facility; and.
-

- (xiii) Provision to have access to the SPCB/PCC/CPCB/MoEF & CC/MoH & FW especially on GPS, online monitoring system and the data.

Besides the provisions suggested in the earlier paras, following important provisions should also be made in a CBWTF:

- (i) A telephone shall be provided and maintained at the facility.
- (ii) A First Aid Box shall be provided and maintained at the CBWTF.
- (iii) Proper lighting shall be provided at the facility.
- (iv) Proper care shall be taken to keep the facility and surroundings free from odors.
- (v) Measures shall be implemented to control pests and insects at the site.
- (vi) Measures shall be implemented to control the escape of litter from the site.
- (vii) Necessary provision shall be made to prevent and control noise generated, if any, due to the activities at the site.
- (viii) Necessary protective gear for the waste handlers shall be provided.
- (ix) Immunization to all the workers of CBWTF against all the diseases including especially Tetanus and Hepatitis -B as stipulated under the BMWM Rules.
- (x) Workers should have provisions such as washing, toilet, and suitable place for eating.
- (xi) Workers should also be provided with N-95 mask besides other PPEs such as hand gloves, gumboots, goggles etc.

Every CBWTF operator shall submit a work-plan to the Prescribed Authority. The work-plan should include the details of facilities at the CBWTF, collection, transportation & storage of the bio-medical wastes, operational details etc.

## 11) Record keeping

Maintenance of records for all operations carried out at the CBWTF is very important to monitor overall operation of the CBWTF. It also helps in submission of the required information to be submitted to the 'Prescribed Authority' by 30<sup>th</sup> June of every year as per the format prescribed under the BMWM Rules or provided by the SPCB/PCC. A well-maintained record of all the activities at the CBWTF also enables the facility operator to produce all information of the activities on demand of the concerned prescribed authority. The record should include all information relating to each activity at the CBWTF site as per BMWM Rules which include accidents occurred (spills, injury, fire accident) and the measures taken and also, however, minimum requirement is outlined below:

---

**a) Records of waste movements**

Daily records shall be maintained for the waste accepted and treated waste removed from the site. This record shall include the following minimum details:

- (i) **Waste accepted:** -Records on day-to-day basis (as per the format given at **Annexure-II**) shall be maintained with respect to the waste collection date, name of the healthcare unit with bar code, waste category as per BMWWM Rules, category-wise quantity of waste accepted, vehicle registration number used for collection of bio-medical waste from member health care facilities, time at which waste collected from member HCFs, name of the vehicle driver and his signature and waste receiving date & time (at CBWTF site). Similar information to be acknowledged to the member health care facility by the CBWTF operator on daily basis.
- (ii) **Treated waste to be disposed:-** Date, treated waste type, Quantity, vehicle number, disposal as stipulated under BMWWM Rules.

**b) Logbook for the treatment equipment**

A logbook shall be maintained for each treatment equipment installed at the site and shall include the following:

- (i) The weight of each batch.
- (ii) The categories of waste as per the Rules.
- (iii) The time, date and duration of each treatment cycle and total hours of operations.
- (iv) The complete details of all operational parameters during each cycle.

Log book to be maintained for operating the incinerator/plasma pyrolysis as well as the autoclave as per the formats given at **Annexure -III**.

**c) Monitoring and reporting of operations in the CBWTF:**

The monitoring of the key operating parameters of treatment equipment provides several benefits. First, monitoring provides the operator with information needed to make decisions on necessary combustion control adjustments. Second, properly maintained monitoring records can provide useful information for identifying operating trends and potential maintenance problems. Following are the suggested parameters for monitoring of the treatment equipment

---

**(i) Monitoring of operating parameters of the incinerator/plasma pyrolysis:**

Following operating parameters can be monitored in case of incinerator/plasma pyrolysis:

- Waste charge rate.
- Combustion gas temperature in primary and secondary chamber as well as the temperature of the stack exit gas (flue gas).
- Condition of the draft (negative draft in primary chamber).
- Combustion gas oxygen level in primary and secondary chamber as well as stack exit gas.
- Air flow rate through the incinerator/plasma pyrolysis.
- Carbon-Di-Oxide (CO<sub>2</sub>), Oxygen (O<sub>2</sub>) and Carbon Monoxide (CO) level in the flue gas.
- Quantity of auxiliary fuel usage as well as the power consumption (in every batch).
- Pressure drop in the primary chamber and APCD attached with the incinerator/plasma pyrolysis and
- Bottom ash or slag quality (for Total Organic Carbon (TOC) as well as loss on ignition and the hazardous constituents (at least once in a quarter).

**(ii) Monitoring of operating parameters of the Autoclave:** Following operating parameters can be monitored during the sterilization using autoclave:

- Time at which sterilization started and time at which sterilization completed.
- Temperature conditions maintained throughout the sterilization
- Conditions of pressure maintained throughout the sterilization
- Duration of sterilization
- Validation test results

Records concerning the above parameters need to be maintained and checked periodically for taking remedial measures during the operation of the incinerator or plasma pyrolysis or autoclave. In case of other treatment processes, the operational conditions as well as the efficacy tests to be complied with as per the standards prescribed under the BMW Rules.

**(iii) Frequency of monitoring:**

The CBWTF operator shall carry out following tests through a NABL approved laboratory or a laboratory approved under the Environment (Protection) Act, 1986, as

---

per the frequency stipulated under the BMWM Rules or as prescribed by the SPCB/PCC and record of such analysis results shall be maintained and submitted to the prescribed authority (SPCB/PCC), as suggested below:

- **Liquid effluent:** Parameters such as pH, Suspended Solids, Oil & Grease, BOD, COD, Bio-assay for liquid effluent being discharged from the CBWTF be monitored as per the Consent conditions or once in a quarter and such records maintained and submitted to SPCB/PCC.

- **Stack emission monitoring:**

In case of the BMW incinerators which came after 28.03.2016, the Stack Emission shall be monitored (under optimum capacity) for parameters such as Particulate Matter, HCl, NO<sub>x</sub>, Hg & compounds and combustion efficiency *once in three months* as required under schedule II of the Bio-medical Waste Management Rules 2016 (All monitored values shall be corrected to 11% Oxygen on dry basis). In case of dioxins and furans, monitoring should be done *once in a year* (monitored values shall be corrected to 11% Oxygen on dry basis). In case of the incinerators (existing prior to the notification of BMWM Rules, 2016), new incinerators standards are required to be complied within two years i.e., by 27.03.2018.

- **Validation test of autoclave/microwave/chemical treatment/dry heat sterilization:**

Suggested validation test for treatment of bio-medical waste by autoclave/microwave/chemical treatment/Dry heat sterilization is given in **Table 1**.

---

**Table 1: Suggested validation test for treatment of bio-medical waste by autoclave/microwave/chemical treatment/Dry heat sterilization**

S. No	Type of equipment used for treatment of bio-medical waste	Type of Validation Test	Frequency
(i)	Autoclave	(i) biological indicator strips or vials <i>Geobacillus stearothermophilus</i> spores with at least $1 \times 10^6$ spores),	once in three months
		(ii) chemical indicator strip or tape	each batch of waste treated
(ii)	Microwave	<i>Bacillus atrophaeus</i> spores using vials or spore strips with at least $1 \times 10^4$ spores per detachable strip	Recommended: once in three months
(iii)	Chemical treatment followed by shredding	<i>Bacillus Subtilis</i> (ATCC 19659)- 4 Log <sub>10</sub> reduction or greater	Once in a week
(iv)	Dry heat sterilisation	consistently kill the biological indicator <i>Geobacillus Stearothermophillus</i> or <i>Bacillus Atropheaus</i> spores using vials with at least 6 log <sub>10</sub> spores per ml.	Once in three months
		A chemical indicator strip or tape	Once in a week

**d) Site Records:**

Site records shall include the following:

- (i) All the approvals obtained from other concerned departments other than the prescribed authority;
- (ii) Details of construction or engineering works;
- (iii) Maintenance schedule, breakdowns/trouble shootings and remedial actions;
- (iv) Emergencies;
- (v) Incidents of unacceptable waste received and the action taken; and
- (vi) Details of site inspections by the officials of the regulatory authorities, purpose of visits with date and necessary actions initiated on the observations.

---

Daily, monthly and annual summary records of all the above shall be maintained and made available at the site for inspection and same submitted whenever required by an authorized official of the concerned regulatory authorities.

**12) Collection and transportation of bio-medical waste**

The collection and transportation of bio-medical waste shall be carried out in a manner so as to prevent any possible hazard to human health and environment. Collection and transportation are the two operations where the chances of segregated bio-medical waste coming in contact with the public, rag pickers, animals/birds, etc. are high. Therefore, all care shall be taken to ensure that the segregated bio-medical waste handed over by the healthcare units reach CBWTF without any damage, spillage or unauthorized access by public, animals etc. A responsible person from the CBWTF operator shall always accompany the vehicle to supervise the collection and transportation of bio-medical waste. Also, the private transport vehicles should not be authorised by the SPCBs/PCCs only for transportation of the Bio-medical Waste. The CBWTF operator should be made responsible for collection and transportation of bio-medical waste.

**a) Collection of bio-medical waste:**

Generator of the bio-medical waste is responsible for providing segregated waste in accordance with the provisions of the Bio-medical Waste Management Rules, 2016, to the CBWTF operator. Dedicated temporary storage at healthcare unit shall be designated. The coloured bags handed over by the healthcare units shall be collected in similar coloured containers with proper cover. Each bag shall be labeled as per Schedule IV of the Bio-medical Waste Management Rules as well as with bar coding system (to be complied by the occupier or operator of a CBWTF as per BMWM Rules) so that at any time, the healthcare units can be traced back that are not segregating the bio-medical wastes as per BMWM Rules. The coloured containers should be strong enough to withstand any possible damage that may occur during loading, transportation or unloading of such containers. These containers shall also be labeled as per Schedule IV of the Rules. Sharps shall be collected in puncture resistant container. The person responsible for collection of bio-medical wastes shall also carry a register with him to maintain the records such as name of the healthcare unit, the type and quantity of waste received, time at which waste collected from the member HCF, signature of the authorised person from the healthcare unit etc. During transportation, the containers should be covered in order to prevent exposure of public to odours and contamination.

---

---

**(b) Transportation of the collected bio-medical waste to the CBWTF:**

All the vehicles used by the CBWTF operator shall not be sub-letted or contract vehicles should not be used by the CBWTF operator. All the vehicles owned by the CBWTF operator and intended only for collection of bio-medical waste from the member health care facilities should be registered under the Motor Vehicle Act with the respective RTO/Transport Department and such vehicle numbers should also be registered with the respective SPCB/PCC for the purpose of collection of bio-medical waste from the member health care facilities. The bio-medical waste collected in designated coloured containers shall be transported to the CBWTF in a fully covered vehicle. Such vehicle shall be dedicated for transportation of bio-medical waste only. Depending upon the volume of the wastes to be transported, the vehicle may be a two or three-wheeler, light motor vehicle or heavy duty vehicle. In either case, the vehicle must possess the following:

- (i) Transportation vehicle shall be fitted with GPS to track the movement of the vehicle.
  - (ii) Separate cabins shall be provided for driver/staff as well as for placing the designated colour coded bio-medical waste containers.
  - (iii) Two wheeler registered under the Motor Vehicle Act shall be permitted for collection of bio-medical waste only from the clinics or dispensaries located in places where the lanes are narrow and not easily accessible to four wheeler vehicles. Such two wheeler vehicle (s) should have a provision of a suitable fixed waste collection box marked with bio-hazard symbol, contact details, proper lid, emergency spill collection procedure, first aid box and manifest record in accordance with the BMWM Rules
  - (iv) The base of the waste cabin shall be leak proof to avoid pilferage of liquid during transportation.
  - (v) The waste cabin may be designed for storing waste containers in tiers and also should be provided with a lighting provision.
  - (vi) The waste cabin shall be so designed that it is easy to wash and disinfect.
  - (vii) The inner surface of the waste cabin shall be made of smooth surface to minimize water retention.
-

- 
- (viii) The waste cabin shall have provisions for sufficient openings in the rear and/or sides so that waste containers can be easily loaded and unloaded.
  - (ix) The vehicle shall be labeled with the bio-hazard symbol (as per Schedule IV of the BMWM Rules) and should display the name, address and contact telephone and mobile number of the CBWTF.
  - (x) The vehicle driver should carry always valid registration of the vehicle obtained from the concerned transport authority and also carry valid 'pollution under control certificate' issued by the authorized certificate issuing agency.

Depending upon the area to be covered under the CBWTF, the route of transportation shall be worked out. The transportation routes of the vehicle shall be designed for optimum travel distance and to cover all member healthcare units of the CBWTF. The CBWTF operator should ensure online and real time tracking & monitoring provisions (GPS provision) should be given access with passwords to the SPCB/PCC and CPCB to cross check the movement of the transportation vehicles on any time by the SPCB/PCC/CPCB. As far as possible, the transportation shall be carried out during non-peak traffic hours. If the area to be covered is very large, a satellite station may be established to store the bio-medical waste collected from the adjoining areas. The wastes so stored at satellite station may then be transported to the CBWTF in a big vehicle. It shall be ensured that the total time taken from generation of bio-medical waste to its treatment, which also includes collection and transportation time, shall not exceed 48 hours.

### 13) Disposal option of solid waste generated from the CBWTF

Treated plastic waste, incineration ash, treated waste sharps and glass waste, Oil & Grease waste and ETP sludge are generally generated from the CBWTF from the treatment systems such as autoclaving/microwaving, incineration, chemical disinfection and effluent treatment plant respectively. The treated bio-medical waste shall be disposed as per the options suggested in the **Table 2** given below:

---

**Table 2: Suggested Disposal option of solid waste generated from the CBWTF**

Sl. No.	Treated Waste Category	Suggested Treatment and Disposal Options
1.	Plastic wastes after disinfection and shredding	Plastic waste should not be sent to landfill sites. Treated plastic waste to be (i) sent to registered or authorized recyclers <b>(or)</b> (ii) for energy recovery <b>(or)</b> (iii) for diesel or fuel oil recovery <b>(or)</b> (iv) for road making, whichever is possible.
2.	Disinfected Sharps (including needles and syringes) (i.e., Treatment by Autoclaving or Dry Heat Sterilization followed by shredding or mutilation combination of shredding cum autoclaving)	Encapsulation in metal container or cements concrete; (or) sent for final disposal to iron foundries (having consent to operate from the SPCBs/PCCs (or) sanitary landfill or designated concrete waste sharp pit.
3.	Incineration ash	Incineration ash (ash from incineration of any bio-medical waste) shall be disposed through hazardous waste treatment, storage and disposal facility (TSDF), if toxic or hazardous constituents are present beyond the prescribed limits as given in Schedule –II of the Hazardous and Other Waste Management & Transboundary Movement Rules or as revised from time to time.
4.	Other treated solid wastes like Glass waste	Disinfection (by soaking the washed glass waste after cleaning with detergent and Sodium Hypochlorite treatment) or through autoclaving or microwaving or hydroplaning and then sent for recycling.
5.	Oil & Grease	By Incineration
6.	ETP Sludge	After drying in sludge drying beds or removal of moisture content using 'Filter Press' and such ETP sludge shall be given to CBWTF for incineration or to the hazardous waste treatment, storage and disposal facility (HWTSDF) for disposal in Secured Landfill
7.	Hazardous Waste	Disposal through a TSDF located nearby following the manifest as per the Hazardous and Other Waste (Management & Transboundary Movement) Rules, 2016

**14) Cost to be charged by the CBWTF Operator for the Health Care Facilities**

Cost to be charged from the healthcare facilities plays an important role in financial viability and sustainable operation of a CBWTF project, for providing the best treatment services to the Health Care Units and for ensuring compliance to the BMWM Rules. The cost shall be so worked out that neither it becomes a monopoly of the CBWTF operator nor the interest of the CBWTF operator is overlooked. It is recommended that cost to be charged from the healthcare units, depending on the size, no, of beds and the distance from the location of the CBWTF and same shall be worked out in consultation with the concerned SPCB/PCC and the local Medical Association, keeping in view the following options:

- (a) In case of non-bedded health care units, fixed charges depending on the average quantity of waste generation per day, in case of the nursing homes/clinics/sample collection Centres /Dental Centres, dispensary, pathological laboratory, blood banks, and other non-bedded hospitals irrespective of their system of medicine including ayush hospitals.
- (b) In case of bedded hospitals, fixed charges per bed per day basis and based on the no. of beds for which consents under the Water Act, 1974/Air Act, 1981 and authorization granted under the BMWM Rules, by the prescribed authority

**Note:**

- (i) *Rates are required to be revised once in a year based on the Wholesale Price Index (WPI Index) or Consumer Price Index (CPI Index) (considering the prevailing market price especially in respect of the labour expenses, diesel prices, electricity, operating cost etc.), by the State Advisory Committee in consultation with the concerned SPCB/PCC, local Medical Association and the representatives of the CBWTF Association*
- (ii) *The Health Care Facilities are required to ensure timely payments to the CBWTFs for ensuring timely treatment services in compliance to the BMWM Rules as well as agreement made with the concerned CBWTF Operator.*

**15) Check list for development of CBWTF**

The criteria for development of CBWTF have been discussed in detail in the

---

Previous sections. However, to have at a glance check in developing CBWTF, checklist is reproduced for convenience and is annexed **(Annexure-IV)**.

**16) Periodic inspection/monitoring or performance evaluation of the CBWTF**

To have uniformity in performance evaluation of the CBWTF throughout the country, a check list for performance evaluation of the CBWTF for carrying out inspection/monitoring/compliance verification has been prepared and is annexed **(Annexure -V)**. All the prescribed authority (SPCB/PCC) shall inspect the CBWTF at least once in six months located in the respective State/UT and a copy of the inspection reports shall be submitted to CPCB and MoEF & CC along with a copy of the action taken for ensuring compliance to the BMW/M Rules and CPCB guidelines issued from time to time and also such information is required to be uploaded in SPCB/PCC website. CPCB shall carryout random inspection of the CBWTFs once in a quarter and any violations observed further actions shall be initiated by CPCB if required under the Environment (Protection) Act, 1986.

-- OO --

---

**Annexure-I**

**Coverage area-wise gap analysis for assessing additional BMW treatment capacity requirement**

S. No	Coverage area (pl. indicate areas covered by a CBWTF in the State/UT)	No. of HCFs		No. of Beds covered	Total estimated BMW generation in Kg/day	Total existing treatment capacity in Kg					Total BMW Treated and Disposed in Kg/day	Gap between total BMW Generation and the Existing BMW Treatment Capacity in Kg	Remarks (Whether additional Treatment Capacity is required or not)	
		Bedded	Non-bedded			Incineration	Autoclaving/ Hydroclaving /microwaving	Chemical disinfection	Deep burial	Any other mode of disposal			Yes	No
(1)	(2)	(3)	(4)	(5)	(6)	(7)	(8)	(9)	(10)	(11)	(12)	(13)	(14)	(15)

*Note: Above gap analysis coverage area-wise is required to be prepared once in five years and should be shown or depicted in a Map of State/UT.*

**Annexure- II****Format for maintaining the records by the CBWTF Operator alongwith the transportation Vehicle used for collection of bio-medical waste from the member HCFs**

Name of the CBWTF :  
 Address of the CBWTF with contact details :  
 Vehicle Registration Number (certificate to be carried by the vehicle driver) :  
 Route covered (indicate places) by the vehicle :

Date	Vehicle number and the Time of arrival of the vehicle	Vehicle meter readings in KM		Name of the HCF with address and the bar code number from whom waste collected	Category-wise quantity of bio-medical waste received in kg				Total BMW collected by the CBWTF		Name of the Vehicle driver with	Signatures	
		Initial	Final		Yellow	Red	Blue	Out dated medicines	White- Waste Sharps	Total No. of Bags		Total waste	Vehicle Driver
(1)	(2)	(3)	(4)	(5)	(6)	(7)	(8)	(9)	(10)	(11)	(12)	(13)	(14)

*Note: Above format is required to be maintained in duplicate both by the CBWTF Operator and the member HCF*

### Annexure - III Log book for Operating the Incinerator/Plasma Pyrolysis

Date	Time of operation of the Incineration		Quantity of hourly BMW charged in Kg (Total BMW charged in a day in Kg)	Temperature maintained in °C		Negative draft in primary chamber (in mm of water column) (Pl. indicate range i.e., min. to max)	Pressure drop across APCD (in mm of water column) (Pl. indicate range i.e., min. to max.)	p <sup>H</sup> level of scrubbed liquid used (Pl. indicate range - min. to max.)	Average values of flue gas analysis results (continuous online ) observed during the incineration/plasma pyrolysis process operation			Consumption of electricity/ Diesel whichever is applicable			Net Quantity of bio-medical waste received in Kg	Net Quantity of bio-medical waste left over in a day (in Kg)		
	Start	End		Primary Chamber	Secondary Chamber				After scrubbing in stack gas	CO in mg/Nm <sup>3</sup>	O <sub>2</sub> in %	CO <sub>2</sub> in %	% combustion Efficiency	Power (Indicate meter reading) Initial reading			Final reading	Diesel in liters (pl. indicate daily or weekly diesel consumption)
(1)	(2)	(3)	(4)	(5)	(6)	(7)	(8)	(9)	(10)	(11)	(12)	(13)	(14)	(15)	(16)	(17)	(18)	(19)

*Note: Fill the details whichever is applicable*

### Log Book for Operating the Autoclave/Hydroclave

Date	Time of operation of the Autoclave or Hydroclave		Batch number	Quantity of waste feeding per batch in Kg (Total waste treated by autoclaving/ hydroclave in Kg)	Temperature and Pressure in- every ten-minutes		Strip test result (pl. paste the strip test for each batch with a proof)	Consumption of electricity (indicate electricity meter reading)		Net Quantity of waste received in Kg	Net Quantity of Waste left over in Kg
	Start	End			Temperature in °C	Pressure in psi		Initial reading	Final reading		
(1)	(2)	(3)	(4)	(5)	(6)	(7)	(8)	(9)	(10)	(11)	(12)=(11)-(5)

**Annexure – IV****Check List for Development of a Common Bio-medical Waste Treatment and Disposal Facility & For issuing 'Consent to Establishment under Water & Air Acts**

- 
1. Name of the Proponent :
  2. Proposed location of the CBWTF :
  3. No. of HCFs in the locality :
  4. No. beds :
  5. Total Bio-medical Waste Generation in kg/day :
    - (i) Incinerable in kg/day :
    - (ii) Autoclavable in kg/day :
    - (iii) Glass waste in kg/day :
    - (iv) Waste sharps in kg/day :
  
  6. **Proposed location of the CBWTDF:** located away from
    - a) Residential area : Yes  No
    - b) Sensitive area : Yes  No
    - c) Industrial area : Yes  No
    - d) Is it as a part of TSDF : Yes  No
    - e) Is the facility proposed in Hilly areas : Yes  No
    - d) Buffer distance of 500 m available : Yes  No
  
  7. **Proposed land area for CBWTF:**
    - a) Area about 1 acre : Yes  No
    - b) Area less than 1 Acre : Yes  No
    - c) Area more than 1 Acre : Yes  No
  
  8. **Proposed coverage area of the CBWTF:**
    - a) Any facility located upto a radius of 75 KM from the proposed locality : Yes  No
    - b) No. of beds covered by the existing facility/proposed facility:
      - (i) more than 10, 000 beds : Yes  No
      - (ii) less than 10,000 beds : Yes  No
    - c) Is there any CBWTF within the radius of 75 KM : Yes  No
    - d) BMW Waste generation in a coverage area under consideration: ..... Kg/day
-

- e) Existing CBWTF treatment Capacity :
- (a) Incineration/plasma pyrolysis :..... Kg/day
- (b) Autoclave/hydroclave : .....Kg/day
- f) Is locality requires any additional capacity (within a radius of 75 KMs)?.
- : Yes  No
- (i) If so, indicate reason:.....

**9. Requirement of Treatment Facility:** Following treatment facilities shall be provided in a CBWTF:

- a) Incineration : Yes  No
- b) Autoclave (Pre-vacuum horizontal feeding) / Hydroclave / Microwave. : Yes  No
- c) Shredder : Yes  No
- d) Sharp pit (with drawing details) : Yes  No
- e) Provision for floor washing/vehicle washing: Yes  No
- f) Effluent Treatment Plant : Yes  No
- g) Secured land fill/Disposal of ash in TSDF : Yes  No
- h) Other provisions as per CPCB guidelines : Yes  No

**10. Segregation**

- (i). Segregation shall be as per the Bio-medical Waste Management Rules, 2016 as amended as well as compatible with treatment facilities at CBWTF
- (ii). Occupier/Generator is responsible for providing segregated waste to the operator.

**11. Collection**

- (i) Respective coloured bags provided with bar code should be kept in similar coloured container i.e. coloured bags shall not be directly kept in vehicle.
- (ii) Sharps shall be collected in puncture resistant, leak proof, rigid containers.
- (iii) Temporary storage at healthcare unit shall be designated.

**12. Transport Vehicle**

- (I) Dedicated vehicles for collection of Bio-medical waste : Yes  No
- (II) Separate cabins shall be provided for driver/staff and the bio-medical waste containers : Yes  No

- (III) The base of the waste cabin shall be leak proof to avoid pilferage of liquid during transportation : Yes  No
- (I) The waste cabin may be designed for storing waste containers in tiers : Yes  No
- (V) The waste cabin shall be so designed that it is easy to wash and disinfect. : Yes  No
- (VI) The inner surface of the waste cabin shall be made of smooth surface to minimize water retention : Yes  No
- (VII) The waste cabin shall have provisions of sufficient openings in the rear and/or sides so that waste containers can be easily loaded and unloaded : Yes  No
- (VIII) The vehicle shall be labeled with the bio-hazard symbol (as per Schedule IV of BMWM Rules) and should display the name, address and telephone number of the CBWTF : Yes  No
- (IX) Other provision as per CPCB guidelines : Yes  No

### 13. Storage

- (I) Sufficient ventilated storage space for untreated and treated bio-medical waste shall be provided. : Yes  No
- (II) The flooring and walls (to a height of 2M from floor) shall be finished with smooth and fine material. There shall be minimum number of joints. : Yes  No

### 14. Record Keeping

- (I) Documents such as collection advice taken from health care units for each category of waste, records of waste movements, logbook for the equipment and site records shall be maintained. : Yes  No
- (II) All the record (five year) shall be available at the CBWTF site for inspection. : Yes  No

### 15. Proposed Treated Waste Disposal method:

- (i). Incineration ash - Secured landfill/near by TSDF : Yes  No
- (ii). Plastic waste after disinfection and shredding –Registered Recycling Unit : Yes  No
- (iii). Sharps, after disinfection ( if encapsulated ) - Municipal landfill : Yes  No
- (iv). Treated wastewater –Discharge into sewer/drain or recycling in APCD

- (v). Oil & grease –By incineration: : Yes  No
- (VI). Any other mode of disposal of recyclable waste: : Yes  No
- (If so, pl. indicate .....)

**16. Estimated energy consumption and fuel consumption per month :**

- (i) Estimated energy consumption per month
- (a) General lighting in the facility :
- (b) Incinerator :
- (c) Autoclave/microwave :
- (d) Shredder :
- (e) ETP :
- (f) Any other :
- (ii) Estimated fuel consumption:
- (a) Diesel consumption :..... in Kl per month
- (b) No. of hours of operation of DG Set :
- (c) No. of hours of incineration :

17. Whether the proponent obtained necessary approvals from the concerned departments as required : Yes  No

(i) If yes, attach details

18. Whether the proponent obtained EC as per EIA 2006 and the amendments made thereof : Yes  No

(i) If yes, attach a copy of the EC obtained from the concerned

19. Whether the proposal recommended for issuing consent to establish : Yes  No

**(Signature of the official verified with date)**

## Annexure – V

**Check List for Performance Evaluation of the  
Common Bio-medical Waste Treatment and Disposal Facility (CBWTF)**

S.No.	Details	Particulars
01.	Name of CBWTF with contact details	:
02.	Date of visit	:
03.	Location details of the CBWTF	: <ul style="list-style-type: none"> <li>a) Near to Residential area: :Yes <input type="checkbox"/> No <input type="checkbox"/></li> <li>b) In/near Sensitive area: Yes <input type="checkbox"/> No <input type="checkbox"/></li> <li>c) In Industrial area : Yes <input type="checkbox"/> No <input type="checkbox"/></li> <li>d) Is there a buffer zone of 500 m: Yes <input type="checkbox"/> No <input type="checkbox"/> Indicate exact distance: in KM</li> <li>e) Is it as a part of TSDF: Yes <input type="checkbox"/> No <input type="checkbox"/> If so, distance of TSDF from the nearest CBWTF: .....KM..</li> <li>f) Is the facility proposed in Metropolitan city: Yes <input type="checkbox"/> No <input type="checkbox"/> (i)Name of the City: ..... (ii)Population of the City (as per latest census): .....</li> <li>g) Is the facility proposed in Hilly area : Yes <input type="checkbox"/> No <input type="checkbox"/> (i)Name of the Town/City: .....</li> </ul>
04	Month / year of establishment and the Consents status	: Establishment Month/Year :
05.	CBWTF set up by	:
06.	CBWTF operated by	:
07.	Total number of healthcare facilities and beds covered (as on date of visit)	: <ul style="list-style-type: none"> <li>No. of HCFs :</li> <li>No. of Beds :</li> <li>No. of HCFs and beds upto 75 KM radius:</li> </ul>
08.	Total BMW Treatment Capacity of CBWTF (in kg / day)	: <ul style="list-style-type: none"> <li>Incineration :</li> <li>Autoclave :</li> <li>Any other treatment and disposal:</li> </ul>

S.No.	Details	Particulars
09.	<b>Consents and Authorization details :</b>	
9.1	Consent under Water (Prevention and Control of Pollution) Act, 1974 :	<input type="checkbox"/> Applied for <input type="checkbox"/> Not Applied for <input type="checkbox"/> Possess Valid Consent <input type="checkbox"/> Not renewed <input type="checkbox"/> No consent If obtained: Consent is valid upto ..... and issued by .....SPCB/PCC vide letter dated .....
9.2	Consent under Air (Prevention and Control of Pollution) Act, 1981 :	<input type="checkbox"/> Applied for <input type="checkbox"/> Not Applied for <input type="checkbox"/> Possess Valid Consent <input type="checkbox"/> Not renewed <input type="checkbox"/> No consent If obtained: Consent is valid upto ..... and issued by .....SPCB/PCC vide letter dated .....
9.3	<b>Environmental Clearance ( EC)</b>	<input type="checkbox"/> Applied for <input type="checkbox"/> Not applied <input type="checkbox"/> Obtained <input type="checkbox"/> Not obtained If obtained: EC issued by SEIAA or MoEF& CC vide letter dated .....
9.4	Authorization under BMW Rules, 1998 :	<input type="checkbox"/> Applied for <input type="checkbox"/> Not Applied for <input type="checkbox"/> Possess Valid Authorisation <input type="checkbox"/> Not renewed <input type="checkbox"/> No Authorisation If obtained: Authorisation is valid upto ..... and issued by .....SPCB/PCC vide letter dated .....
10.	Investment in setting up the CBWTF :	
11.	Area of plot size for CBWTF (Sq. ft.) :	
12	Annual Report submission for the year .....	Submitted before due date : :Yes <input type="checkbox"/> No <input type="checkbox"/> If yes, provide details of waste collected, received and treated & disposed of: .....
12.	Coverage area of CBWTF (radius in KM covered)	Coverage area upto 75 km radius: Yes <input type="checkbox"/> No <input type="checkbox"/>
13.	Name of Districts/Cities / places being covered	(Pl. indicate Districts or places covered:..... .....) W.r.to the CBWTF (i) Farthest HCF located at :.....KM (ii) Nearest HCF located at :.....KM.

S.No.	Details	Particulars
14.	Daily operation schedule (timings)	(i) Collection: ...AM to .... PM. (ii) Incineration:....AM to ....PM (iii) Whether waste from member HCFs collected in holidays: <input type="checkbox"/> Yes <input type="checkbox"/> No
15.	Cost charged to the healthcare facilities	(i) Charges in Rs..... (ii) Is the cost to be levied suggested by: .....Organisation
<b>16.</b>	<b>Total quantity of bio-medical waste treated: kg/day (avg.)</b>	
16.1	Incinerable	: ..... %
16.2	Autoclaving	: .....%
16.3	Others (please specify waste type-wise)	: .....%
<b>17.</b>	<b>Staff involvement in CBWTF operation (number of persons):</b>	
17.1	Managerial Administration /	:
17.2	Equipment operations	:
17.3	Transportation of BMW	: No. of Drivers: No. of Helpers:
17.4	Sanitation and others	:
17.5	Total persons excluding managers	:
<b>18.0</b>	<b>Collection and Transportation of bio-medical waste from member HCFs :</b>	
18.1	No. of Vehicles used for collection of waste from member HCFs	: (i) Four Wheelers: .....Nos and Vehicle Numbers: ..... (ii) Two Wheelers :.....Nos and Vehicle Numbers:.....
18.2	Vehicles are labeled as per BMWM Rules, 2016	: <input type="checkbox"/> Satisfactory <input type="checkbox"/> No satisfactory
18.3	Vehicles used are as per CPCB Guidelines	: <input type="checkbox"/> Satisfactory <input type="checkbox"/> No satisfactory
18.4	Vehicles attached with the GPS provision as per BMWM Rules 2016	: <input type="checkbox"/> Satisfactory <input type="checkbox"/> No satisfactory
18.5	Whether waste collected from member HCFs adopted Bar coding system ?	: <input type="checkbox"/> Yes <input type="checkbox"/> No

S.No.	Details	Particulars												
19.0	Temporary untreated waste storage area	: <input type="checkbox"/> Satisfactory <input type="checkbox"/> No satisfactory												
20.0	Mode of conveyance of bio-medical waste from untreated waste storage area to the treatment equipment within the CBWTF	: <input type="checkbox"/> Closed Trolley/Pull cart with bio-hazard symbol <input type="checkbox"/> No Closed Trolley/Pull cart <input type="checkbox"/> Others like .....												
<b>21.0</b>	<b>Treatment equipment installed at CBWTF</b>													
21.1	Incinerator/plasma pyrolysis capacity and make	: (i) No. of Incinerators including standby: (ii) Incineration capacity: ..... kg /hr .....Kg/day.												
21.2	Daily Operation schedule of the incinerator /plasma pyrolysis (timings)	: .....AM to .....PM (or) .....PM to .....AM Whether bio-medical waste collected from member HCFs is treated during holidays: Yes <input type="checkbox"/> No <input type="checkbox"/>												
21.3	Consumption of auxiliary fuels	: <table border="1"> <thead> <tr> <th>S. No</th> <th>Type of Fuel</th> <th>Consumption Quantity in liters per day</th> <th>Bill numbers of purchase of fuel</th> </tr> </thead> <tbody> <tr> <td>a)</td> <td></td> <td></td> <td></td> </tr> <tr> <td>b)</td> <td></td> <td></td> <td></td> </tr> </tbody> </table>	S. No	Type of Fuel	Consumption Quantity in liters per day	Bill numbers of purchase of fuel	a)				b)			
S. No	Type of Fuel	Consumption Quantity in liters per day	Bill numbers of purchase of fuel											
a)														
b)														
21.4	Stack attached with the incinerator /plasma pyrolysis	: (i) Stack Diameter: m (ii) Stack Height : m above Ground Level												
21.5	Monitoring provision attached with the stack	: <input type="checkbox"/> Platform <input type="checkbox"/> Porthole <input type="checkbox"/> access to the platform (Steps/Monkey Ladder/any other.....)												
21.6	Is stack monitoring provision satisfactory and as per CPCB guidelines	: <input type="checkbox"/> Yes <input type="checkbox"/> No												
21.7	air pollution control systems attached with the incinerator/plasma pyrolysis	: (i) Quenching : <input type="checkbox"/> Yes <input type="checkbox"/> No (ii) Venturi scrubber : <input type="checkbox"/> Yes <input type="checkbox"/> No (iii) Droplet separator : <input type="checkbox"/> Yes <input type="checkbox"/> No (iv) Mist eliminator : <input type="checkbox"/> Yes <input type="checkbox"/> No (v) Filters : <input type="checkbox"/> Yes <input type="checkbox"/> No (vi) Lime and Activated Carbon injection: : <input type="checkbox"/> Yes <input type="checkbox"/> No												

S.No.	Details	Particulars
		(vii) ID Fan : <input type="checkbox"/> Yes <input type="checkbox"/> No (viii) Any other : (Pl. indicate)
21.8	Waste feeding mechanism	(i) Manual feeding : <input type="checkbox"/> Yes <input type="checkbox"/> No (ii) PLC based Automatic feeding : <input type="checkbox"/> Yes <input type="checkbox"/> No
21.9	Is PLC and automatic recording system (for recording operating parameters of the incinerator) attached with the incinerator/plasma pyrolysis	(i) PLC synchronized with waste feeding mechanism & in working condition: <input type="checkbox"/> Yes <input type="checkbox"/> No (I) PLC synchronized and recording system attached with incinerator and in working condition: <input type="checkbox"/> Yes <input type="checkbox"/> No
21.10	Operational conditions of the Incineration/plasma pyrolysis as observed during the visit	(i) Whether burners in working condition: <input type="checkbox"/> Yes <input type="checkbox"/> No (ii) Temperature maintained in Primary Chamber (range) : ..... <sup>o</sup> C (iii) Temperature maintained in Secondary Chamber (range):..... <sup>o</sup> C (iv) Negative draft in Primacy Chamber : .....mm of water column (v) Pressure drop in the Venturi: ..... mm of water column
21.11	Is continuous on-line monitoring system/Flue gas analyser attached with the incinerator/plasma pyrolysis for flue gas analysis ( i.e CO, O <sub>2</sub> and CO <sub>2</sub> )	(i) Is continuous online monitoring system (COMS) attached with incinerator: <input type="checkbox"/> Yes <input type="checkbox"/> No (ii) Observed values of flue gas parameters: CO <sub>2</sub> : .%, O <sub>2</sub> : ..... % and CO: ..... % (iii) Observed Combustion Efficiency: .....% (iv) Observed values of stack emissions as per COMS .....
21.12	Emergency and Fire safety measures adopted within the facility is adequate	Is Emergency stack attached with the incinerator: <input type="checkbox"/> Yes <input type="checkbox"/> No Whether fire safety measures adopted (Fire Extinguishers, Sand buckets etc.): <input type="checkbox"/> Yes <input type="checkbox"/> No
21.13	Log book for incinerator/ plasma pyrolysis is maintained and satisfactory	Log Book Maintained: <input type="checkbox"/> Yes <input type="checkbox"/> No Log Book Maintained is satisfactory : <input type="checkbox"/> Yes <input type="checkbox"/> No

S.No.	Details	Particulars
21.14	Details of heat recovery system installed with incinerator/plasma pyrolysis	: <input type="checkbox"/> Yes <input type="checkbox"/> No
<b>22.0</b>	<b>Capacity of autoclave and-- make</b>	: Autoclave of capacity .....kg/cycle and make ..... installed.
22.1	Operating conditions of autoclave/microwave as observed during the visit	: Operating parameters observed: (i) Temperature : in °C (ii) Pressure : in psi (iii) Residence time : in minutes
22.2	Provision made for the autoclave /microwave	: Trolley for waste feeding : <input type="checkbox"/> Yes <input type="checkbox"/> No Graphic or computer recording device attached: <input type="checkbox"/> Yes <input type="checkbox"/> No
22.3	Spore test or strip test conducted regularly and records maintained	: <input type="checkbox"/> Yes <input type="checkbox"/> No Pl. indicate frequency of Strip test conducted: every batch /once in a week /quarterly /yearly Pl. indicate frequency of Spore test conducted: every batch /once in a week /quarterly /yearly
22.4	Performance of autoclave by spore testing or routine test	: <input type="checkbox"/> Satisfactory <input type="checkbox"/> Not satisfactory
22.5	Log book maintained for autoclave is satisfactory	: Log Book Maintained: <input type="checkbox"/> Yes <input type="checkbox"/> No Log Book Maintained is satisfactory : <input type="checkbox"/> Yes <input type="checkbox"/> No
<b>23.0</b>	<b>Capacity of shredder and make</b>	: ..... kg/hr. Self-designed & got fabricated locally.
<b>24.0</b>	Details of sharp pit / Encapsulation facility	: (i) Sharp Pit provided : <input type="checkbox"/> Yes <input type="checkbox"/> No (ii) Is it as per CPCB guideline : <input type="checkbox"/> Yes <input type="checkbox"/> No (iii) Records maintained : <input type="checkbox"/> Yes <input type="checkbox"/> No (iv) Total quantity of waste sharps stored: (v) Total quantity of waste sharps treated and disposed:
<b>25.0</b>	<b>Water Balance</b>	
25.1	Source and quantity of water intake per day (cu.m / day)	: Water consumption source: ..... Water is drawn at ..... KLD approximately. Is magnetic water flow meter attached to the water source/water storage tank : <input type="checkbox"/> Yes <input type="checkbox"/> No

S.No.	Details	Particulars														
		<p>Magnetic water flow meter readings as per record (for last month):            1<sup>st</sup> Day of Month :            Last day of month :            Magnetic Flow meter as observed during the visit:</p> <table border="1"> <thead> <tr> <th rowspan="2">S. No</th> <th rowspan="2">Month</th> <th colspan="2">Magnetic flow meter reading</th> </tr> <tr> <th>Initial</th> <th>Final</th> </tr> </thead> <tbody> <tr> <td>(1)</td> <td>Previous month .....</td> <td></td> <td></td> </tr> <tr> <td>(2)</td> <td>On the date of visit:.....</td> <td></td> <td></td> </tr> </tbody> </table> <p>If water requirement is met from outside through tankers, pl. provide No. of Tankers procured in a previous six months:             Total quantity of water consumed during the previous six months : .. .... in KLD</p>	S. No	Month	Magnetic flow meter reading		Initial	Final	(1)	Previous month .....			(2)	On the date of visit:.....		
S. No	Month	Magnetic flow meter reading														
		Initial	Final													
(1)	Previous month .....															
(2)	On the date of visit:.....															
25.2	Break up of water usage (such as washing, scrubbing etc.)	: Scrubber – KL/hr or KLD Washing – KLD Disinfections – KLD Gardening – KLD Domestic – KLD														
<b>26.0</b>	<b>Total wastewater effluent generated per day</b>	: About .....KLD generated Quantity of treated water reused/recycled in %: Any other mode of disposal:														
<b>27.</b>	<b>Effluent treatment plant details</b>															
27.1	ETP Capacity	: ..... KL/Cycle														
27.2	Flow Chart of ETP	: ETP comprising of: ..... Unit operations														
27.3	Intake and Discharge of ETP	: (i) Magnetic Flow measuring device provided at the outlet of ETP: <input type="checkbox"/> Yes <input type="checkbox"/> No (ii) Energy meter attached to the ETP: <input type="checkbox"/> Yes <input type="checkbox"/> No (iii) Energy consumed over a period of one month: = ..... Units (iv) pH meter attached at the outlet of ETP: <input type="checkbox"/> Yes <input type="checkbox"/> No														

S.No.	Details	Particulars
27.4	Final mode of disposal of treated water	(i) Is treated wastewater complying with the discharge norms <input type="checkbox"/> Yes <input type="checkbox"/> No (ii) Is Treated water is reused in the scrubber: <input type="checkbox"/> Yes <input type="checkbox"/> No (ii) Is Treated water is reused for gardening: <input type="checkbox"/> Yes <input type="checkbox"/> No (iii) Is Treated water is discharged in drain: <input type="checkbox"/> Yes <input type="checkbox"/> No (iv) Is Treated water is discharged in open area: <input type="checkbox"/> Yes <input type="checkbox"/> No
<b>28.</b>	<b>Status of infrastructure provided (Pl. indicate 'Yes / No' whichever is applicable)</b>	
28.1	Separate treatment equipment room	<input type="checkbox"/> Yes <input type="checkbox"/> No
28.2	Main waste storage room	<input type="checkbox"/> Yes <input type="checkbox"/> No
28.3	Treated waste storage room	<input type="checkbox"/> Yes <input type="checkbox"/> No
28.4	Administrative room	<input type="checkbox"/> Yes <input type="checkbox"/> No
28.5	Generator set	<input type="checkbox"/> Yes <input type="checkbox"/> No
	(i) Capacity	
	(ii) Is Stack attached as per DG Set norms	<input type="checkbox"/> Yes <input type="checkbox"/> No
	(iii) Is Acoustic enclosure provided as per DG Set norms	<input type="checkbox"/> Yes <input type="checkbox"/> No
	(iv) Is DG Set complying to the emissions norms and noise level norms	<input type="checkbox"/> Yes <input type="checkbox"/> No  If so, pl. indicate latest monitoring results: .....
28.6	Site security (high walls, fencing, guarded gates etc.)	High walls on all four sides : <input type="checkbox"/> Yes <input type="checkbox"/> No Fencing on all the sides : <input type="checkbox"/> Yes <input type="checkbox"/> No Guarded Gates : <input type="checkbox"/> Yes <input type="checkbox"/> No Any other observation pl indicate:.....

S.No.	Details		Particulars
28.7	Parking facility	:	<input type="checkbox"/> Yes <input type="checkbox"/> No
28.8	Sign board	:	<input type="checkbox"/> Yes <input type="checkbox"/> No
28.9	Green belt	:	<input type="checkbox"/> Yes <input type="checkbox"/> No
28.10	Washing room	:	<input type="checkbox"/> Yes <input type="checkbox"/> No
28.11	First aid box	:	<input type="checkbox"/> Yes <input type="checkbox"/> No
28.12	Lighting arrangements in the facility	:	<input type="checkbox"/> Yes <input type="checkbox"/> No
28.13	Odour problem remedial measures	:	<input type="checkbox"/> Yes <input type="checkbox"/> No
28.14	Fire fighting and emergency facilities	:	<input type="checkbox"/> Yes <input type="checkbox"/> No
28.15	Measures for control of pests / insects etc.	:	<input type="checkbox"/> Yes <input type="checkbox"/> No
28.16	Protective gear for waste handlers	:	<input type="checkbox"/> Yes <input type="checkbox"/> No
28.17	Telephone facility	:	<input type="checkbox"/> Yes <input type="checkbox"/> No
28.18	Provision of washing, toilets and safe place for eating for the workers		<input type="checkbox"/> Yes <input type="checkbox"/> No
28.19	Fire alarm system provided in the facility		<input type="checkbox"/> Yes <input type="checkbox"/> No
<b>29.</b>	<b>Record maintenance and record keeping details (Pl. indicate 'Yes / No' whichever is applicable)</b>		
29.1	Waste Movement /Manifest record	:	<input type="checkbox"/> Yes <input type="checkbox"/> No
29.2	Log book for treatment equipment	:	<input type="checkbox"/> Yes <input type="checkbox"/> No
29.3	Site records	:	<input type="checkbox"/> Yes <input type="checkbox"/> No
29.4	Incineration ash generation and final disposal records	:	<input type="checkbox"/> Yes <input type="checkbox"/> No
29.5	Treated plastic waste generation and its sale to the registered recycler	:	<input type="checkbox"/> Yes <input type="checkbox"/> No
29.6	Syringes treated and its final disposal record	:	<input type="checkbox"/> Yes <input type="checkbox"/> No

S.No.	Details		Particulars
29.7	Workers health status records		<input type="checkbox"/> Yes <input type="checkbox"/> No
29.8	Workers immunization records		<input type="checkbox"/> Yes <input type="checkbox"/> No
29.9	Medical and para-medical workers training records		<input type="checkbox"/> Yes <input type="checkbox"/> No
29.10	Whether records maintained with regard to the accidents ( such as fire, spills and injury and measures taken)		<input type="checkbox"/> Yes <input type="checkbox"/> No
<b>30.</b>	<b>Collection and transportation status (Yes / No)*</b>		
30.1	Whether waste collected in a container of similar colour with label as per the Rules?	:	<input type="checkbox"/> Yes <input type="checkbox"/> No
30.2	Whether the person who collects BMW maintain a register with him / her?	:	<input type="checkbox"/> Yes <input type="checkbox"/> No
30.3	Has due attention have been given in vehicles to prevent spillage / pilferage/ loading / unloading etc.?	:	<input type="checkbox"/> Yes <input type="checkbox"/> No
30.4	Is the vehicle labeled with the symbol and display the name, address, telephone number etc.?	:	<input type="checkbox"/> Yes <input type="checkbox"/> No
30.5	Does the CBWTF operator use satellite station to store the waste?	:	<input type="checkbox"/> Yes <input type="checkbox"/> No (If yes, give details.....)
30.6	The CBWTF operator collects waste daily or alternate day including	:	<input type="checkbox"/> Yes <input type="checkbox"/> No

S.No.	Details	Particulars
	holidays?	
30.7	Whether waste treatment criterion of 48 hours is complied?	<input type="checkbox"/> Yes <input type="checkbox"/> No
<b>31.</b>	<b>Disposal of treated waste:</b>	
31.1	Plastic waste after treatment	Plastic waste Sold to: M/s. .... and approved by .....SPCB/PCC
31.2	Treated sharps	Treated syringes disposal by:..... or through M/s.....and approved by .....SPCB/PCC
31.3	Incineration ash	Incineration ash disposal by: Disposal in Sanitary Landfill: <input type="checkbox"/> Yes <input type="checkbox"/> No Disposal through TSDF: <input type="checkbox"/> Yes <input type="checkbox"/> No Any other mode :.....
31.4	Other treated solid wastes	
31.5	Oil & grease	
31.6	Treated wastewater	
<b>32.</b>	Frequency of incinerator / autoclave / microwave / hydroclave / ETP discharge effluent testing and name of the laboratory (specify approved or not under E(P) Act, 1986 or NABL Accredited Lab.). Give details of compliance / non-compliance)	(i) Reported monitoring frequency: (ii) Stack monitoring : Quarterly : <input type="checkbox"/> Yes <input type="checkbox"/> No (iii) Waste water : Monthly/Quarterly/Yearly (iv) Incineration ash : Monthly/Quarterly/Yearly (v) Name of the Laboratory conducted test: .....
32.1	Frequency of site inspection by SPCBs/PCCs/CPCB/any other agencies	(i) No. of times in a year inspected by the SPCB/PCC: ..... (ii) No. of times in a year inspected by the CPCB .....

S.No.	Details	Particulars																					
<b>33.</b>	<b>Monitoring Results :</b>																						
33.1	Incinerator stack emission (parameters stipulated in the Rules, temperature attainment in the chambers, residence time in the secondary chamber etc.)	<table border="1"> <thead> <tr> <th>Parameter</th> <th>PM</th> <th>HCl</th> <th>NOx</th> <th>Hg &amp; com-pounds</th> <th>Dioxins and Furans</th> <th>C.E.</th> </tr> </thead> <tbody> <tr> <td>Date</td> <td></td> <td></td> <td></td> <td></td> <td></td> <td></td> </tr> <tr> <td>LIMIT</td> <td>50</td> <td>50</td> <td>400</td> <td>0.05</td> <td>0.1 ng TEQ per Nm<sup>3</sup></td> <td>99.00%</td> </tr> </tbody> </table> <p>Date of monitoring: Note: All values are in mg/Nm<sup>3</sup>, except CE</p>	Parameter	PM	HCl	NOx	Hg & com-pounds	Dioxins and Furans	C.E.	Date							LIMIT	50	50	400	0.05	0.1 ng TEQ per Nm <sup>3</sup>	99.00%
Parameter	PM	HCl	NOx	Hg & com-pounds	Dioxins and Furans	C.E.																	
Date																							
LIMIT	50	50	400	0.05	0.1 ng TEQ per Nm <sup>3</sup>	99.00%																	
33.2	Whether Stack emission norms are complied with by the CBWTF	<input type="checkbox"/> Yes <input type="checkbox"/> No																					
33.3	Incineration ash characteristics	Characteristics as per Schedule –II of HOW (M&TM) Rules,2016 ( Annexure-----) Is it hazardous waste as per HOWM&TM Rules, 2016: <input type="checkbox"/> Yes <input type="checkbox"/> No																					
33.4	ETP inlet/outlet characteristics	All values are in mg/l except pH <table border="1"> <thead> <tr> <th>Parameter</th> <th>pH</th> <th>TSS</th> <th>COD</th> <th>BOD</th> <th>O&amp;G</th> </tr> </thead> <tbody> <tr> <td>ETP Inlet Result</td> <td></td> <td></td> <td></td> <td></td> <td></td> </tr> <tr> <td>ETP Outlet Result</td> <td></td> <td></td> <td></td> <td></td> <td></td> </tr> </tbody> </table>	Parameter	pH	TSS	COD	BOD	O&G	ETP Inlet Result						ETP Outlet Result								
Parameter	pH	TSS	COD	BOD	O&G																		
ETP Inlet Result																							
ETP Outlet Result																							
33.5	Whether liquid effluent discharge norms are complying by the CBWTF	<input type="checkbox"/> Yes <input type="checkbox"/> No																					
33.6	Whether CBWTF is submitting the annual report within the due date for the preceding year	<input type="checkbox"/> Yes <input type="checkbox"/> No If Yes, annual report submitted vide letter No..... dated.....																					
34.	Any other relevant observations	(pl. enclose as annexure)																					
35.	Name of the officials with designation inspected /monitored the CBWTF and the signature																						

## Annexure-VI

### STATIONARY SOURCE EMISSION MONITORING

#### MODIFICATIONS TO BE MADE TO SAMPLING PLATFORM AND SAMPLING PORT HOLE

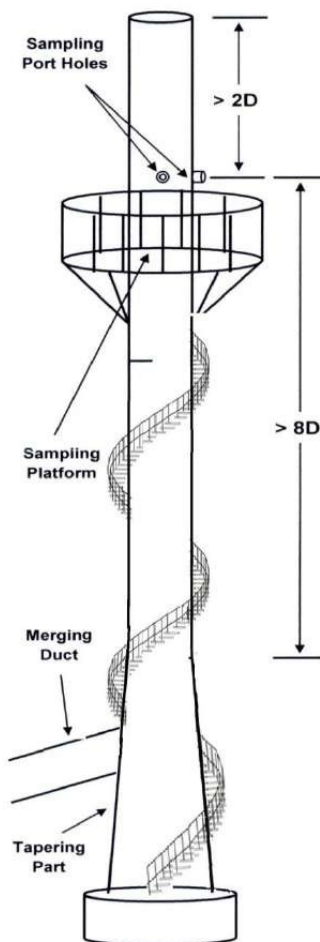

**Number of Port Holes :** Minimum two numbers of Port Holes at 90° apart from each other at a horizontal plane.

**Location of Port Holes :** Minimum 8 times of Internal Diameters of Stack downstream (upward direction of stack) from any duct confluence, bends and tapering & minimum 2 times of Internal Diameters of Stack upstream (downward direction of stack) from stack exit.

**Location of Sampling Platform :** 5 feet upstream (downward direction of stack) from the Port Hole as determined above.

**Port Hole Flange :** If the internal diameter of the flange is 4 inch or more then there is no need to change, if it is less than 4 inch than it has to be replaced with 4 inch flange. The flange should not protrude out more than 6 inches from the outer wall of the stack (it shall be kept as less as possible).

**Sampling Platform Modification :** A semi-circular extension of the existing platform (width extending outward by 6 feet from outside wall of the stack and covering at least one third of the circumference) may be provided for access to both the Port Holes. This area can be extended from the existing Platform and if deemed necessary for safety of the personnel a counter extension in opposite direction may also be provided. The extended Platform shall be strengthened with requisite support from the stack.

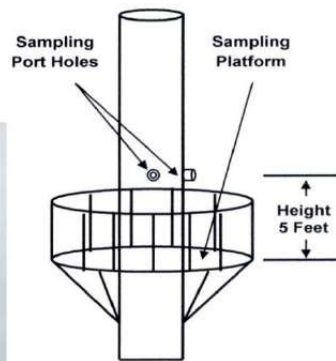

Note: Alternatively, safe access to monitoring platform may be provided with separate scaffolding-cum-staircase arrangement

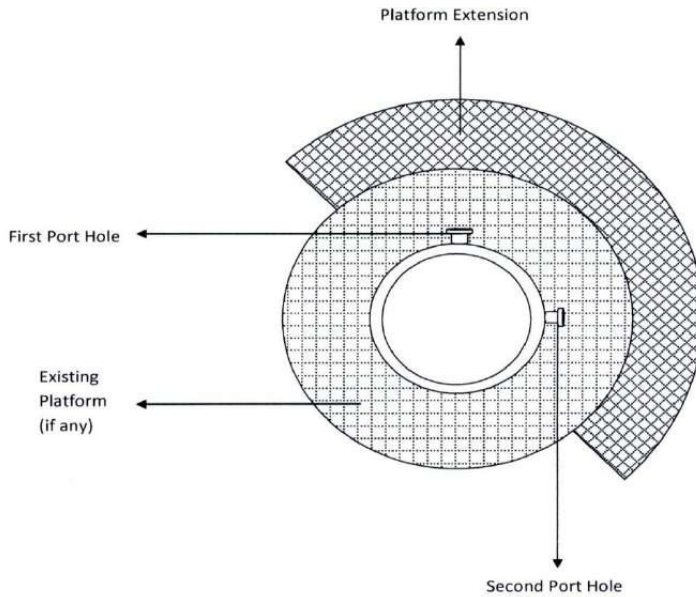

**Sampling Platform Modification / Extension**

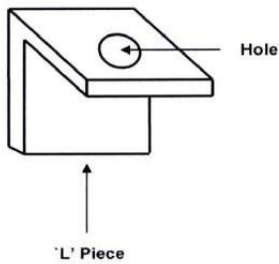

**Fixing of 'L' Pieces on the stack wall :** Two 'L' shaped pieces are to be fixed on the stack wall for mounting the Mono-Rail & Chain (part of the Sampling Kit for movement of sampling Train in & out through the Sampling Port Hole). The 'L' pieces shall be made of approximately 6 mm thick galvanized iron to have 5 cm long arms. One arm of the 'L' piece shall be welded on the stack wall and another arm shall have a hole of 14 mm diameter near the open end. Both the 'L' Pieces shall be welded on the stack wall at specified distances (as shown in the diagram on the next page) from the centre of Sampling Port Hole (in a vertical axis on the Stack Wall).

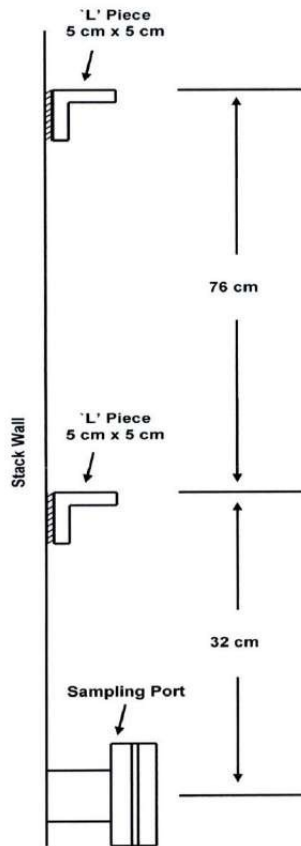

Fixing of 'L' Pieces on the Stack Wall

---

**REFERENCES**

1. Bio-medical Waste Management Rules, 2016.
2. CPCB Guidelines for CBWTFs (2003).
3. CPCB Guidelines for BMW Incinerators (2003).
4. 'Disposal of Bio-medical Waste generated during Universal Immunization Programme' issued by CPCB.
5. 'Guidelines for Environmentally Sound Management of Mercury Waste Generated from the Health Care Facilities' issued by CPCB.
6. Annual Report 2014 submitted to CPCB by the SPCBs/PCCs.
7. Stationary Source Emission Monitoring –Modifications to be made to the Sampling Platform and Sampling Port Hole issued by National Reference Trace Organics Laboratory (NRTOL), CPCB.

-- OO --

---

## Guidelines for Common Bio-medical Waste Treatment and Disposal Facilities



### **CENTRAL POLLUTION CONTROL BOARD**

(Ministry of Environment, Forest and Climate Change)

Parivesh Bhawan, East Arjun Nagar

DELHI -110 032

website: [www.cpcb.nic.in](http://www.cpcb.nic.in)

(April 12, 2025)

---

### Abbreviations

APCD	-	Air Pollution Control Device
BMWM Rules	-	Bio-medical Waste Management Rules, 2016
CBWTF	-	Common Bio-medical Waste Treatment and Disposal Facility
CO	-	Carbon Monoxide
CO <sub>2</sub>	-	Carbon Dioxide
CPCB	-	Central Pollution Control Board
CRZ	-	Coastal Regulation Zone
DG	-	Diesel Generator
EC	-	Environmental Clearance
EIA	-	Environment Impact Assessment
ETP	-	Effluent Treatment Plant
GPS	-	Global Positioning System
HCFs	-	Health Care Facilities
HCl	-	Hydrochloric Acid
HOWM & TM Rules	-	Hazardous and Other Waste (Management & Transboundary Movement) Rules, 2016
MHz	-	Mega Hertz
MoEF& CC	-	Ministry of Environment, Forest & Climate Change
KM	-	Kilometer
KW	-	Kilowatt
MoU	-	Memorandum of Understanding
NABL	-	National Accreditation Board for Testing and Laboratories
NO <sub>x</sub>	-	Oxides of Nitrogen
O <sub>2</sub>	-	Oxygen
PCC	-	Pollution Control Committee
PLC	-	Programmable Logical Control
SEIAA	-	State Environment Impact Assessment Authority
SLF	-	Secured Landfill
SPCB	-	State Pollution Control Board
TSDF	-	Treatment Storage and Disposal Facility
TOC	-	Total Organic Carbon
VOCs	-	Volatile Organic Compounds

## CONTENT

S. No	Description	Page No.
1	Introduction	01
2	Criteria for development of a new Common Bio-medical Waste Treatment and Disposal Facility	02
3	Duties of the operator of a common bio-medical waste treatment and disposal facility	06
4	Applicability of the guidelines	06
5	Environmental laws applicable for commissioning or operation of a CBWTF	07
6	Location criteria	08
7	Land requirement	09
8	Coverage area of CBWTF	10
9	Treatment equipment	10
10	Infrastructure set up	16
11	Record keeping	21
12	Collection and transportation of bio-medical waste	25
13	Disposal option of solid waste generated from CBWTF	29
14	Cost to be charged by the CBWTF operator for the Health Care Facilities	30
15	Check list for development of CBWTF	31
16	Periodic inspection/monitoring or performance evaluation of the CBWTFs	31
	<b>List of Figure and Table</b>	
	<b>Figure 1.</b> Criteria for development of a CBWTF in a coverage area	05
	<b>Table 1:</b> Suggested validation test for treatment of bio-medical waste by autoclave/microwave/chemical treatment/dry heat sterilization	24
	<b>Table 2:</b> Suggested disposal option of solid waste generated from CBWTF	29
	<b>List of Annexure</b>	
	<b>Annexure-I:</b> Coverage area-wise gap analysis for assessing additional BMW treatment capacity requirement	35
	<b>Annexure -II:</b> Format for maintaining the record by the CBWTF Operator along with the transportation vehicle used for collection of the Bio-medical waste from the member HCFs	36
	<b>Annexure -III:</b> Log Book for operating the Incinerator/Plasma Pyrolysis and Autoclave	37
	<b>Annexure -IV:</b> Check list for Development of a CBWTF	38
	<b>Annexure -V:</b> Check list for Performance Evaluation of the CBWTF	43
	<b>Annexure -VI:</b> Stationary Source Emission Monitoring for Dioxins and Furans	56
	<b>Annexure -VII:</b> Details regarding colour and size of bio-hazard symbol and font	59

---

	<b>List of Appendix</b>	
	<b>Appendix I:</b> Methodology to conduct gap analysis with respect to generation and treatment of biomedical waste- Rev.1	32
	<b>References</b>	61

---

---

## 1) Introduction

A Common Bio-medical Waste Treatment and Disposal Facility (CBWTF) is a set up where biomedical waste generated from member health care facilities is imparted necessary treatment to reduce adverse effects that this waste may pose on human health and environment. The treated recyclable waste may finally be sent for disposal in a secured landfill or for recycling.

According to the Bio-medical Waste Management Rules, 2016, "bio-medical waste treatment and disposal facility" means any facility wherein treatment, disposal of bio-medical waste or processes incidental to such treatment and disposal is carried out, and includes common bio-medical waste treatment facilities and "operator of a common bio-medical waste treatment facility" means a person who owns or controls a Common Bio-medical Waste Treatment and Disposal Facility (CBWTF) for the collection, reception, storage, transport, treatment, disposal or any other form of handling of bio-medical waste.

The Bio-medical Waste Management Rules, 2016 (BMWM Rules) restricts occupier for establishment of on-site or captive bio-medical waste treatment and disposal facility, if a service of common bio- medical waste treatment and disposal facility is available within a distance of seventy-five kilometer, as installation of individual treatment facility by health care facility (HCF) requires comparatively high capital investment. In addition, it requires separate dedicated and trained skilled manpower and infrastructure development for proper operation and maintenance of treatment systems. The concept of CBWTF not only addresses such problems but also prevents proliferation of captive treatment facilities in a particular area. In turn, it reduces the monitoring pressure on regulatory agencies. By running the treatment equipment at CBWTF to its full capacity, the cost of treatment of per kilogram of bio-medical waste gets significantly reduced. Its considerable advantages have made CBWTF popular and proven concept in most part of the world.

The CBWTFs are also required to set up based on the need for ensuring environmentally sound management of bio-medical waste keeping in view the techno-economic feasibility and viable operation of the facility with minimal impact on human health and environment.

Since 1998, the CBWTF as an option for treatment of bio-medical waste also been legally introduced in India. Considering the likely impacts that may cause to the

---

patients undergoing treatment because of operation of the captive treatment equipment within the health care facilities (HCFs), now the Bio-medical Waste Management Rules, 2016 recommends the Occupier (i.e., HCF) for ensuring treatment and disposal of generated bio-medical waste through a CBWTF, located within a distance of 75 KM. Further, these rules eased the bottleneck in upbringing the CBWTF by making department in the business allocation of land assignment in the State or UT administration responsible for providing a suitable site (s) within its jurisdiction.

The concept of CBWTF is also being widely accepted in India among the healthcare units, medical associations and entrepreneurs. In order to set up a CBWTF to its maximum perfection, care shall be taken in choosing the right technology, development of CBWTF area, proper designing of transportation system to achieve optimum results etc. Key features of CBWTF have been addressed in the subsequent sections.

To facilitate the treatment and disposal of bio-medical waste generated from the HCFs, at present (as per Annual Report 2023 submitted by the State Pollution Control Boards/Pollution Control Committees), there are 234 no. of CBWTFs in operation and 30 no. of CBWTFs are under construction. Also, the Bio-medical Waste Management Rules, 2016 mandates that the operator of a CBWTF authorised by the prescribed authority is required to take all necessary steps to ensure that the bio-medical waste collected from the occupier is transported, handled, stored, treated and disposed of, without any adverse effect to the human health and the environment, in accordance with the BMW Rules and the guidelines issued by the Central Government or the Central Pollution Control Board (CPCB) from time to time. Therefore, these guidelines have been prepared with an aim to have uniformity in ensuring site selection, allowing and establishment of a state-of-the-art CBWTF, operation as well as verification of compliance to the BMW Rules, 2016 throughout the country. However, any other aspects which are not been covered under these guidelines and needs attention, in such a case, the prescribed authority may take suitable action in the interest of protection of the environment in consultation with MoEF & CC/CPCB. Also, it is pertinent to mention here that these guidelines are mandatory henceforth under the Bio-medical Waste Management Rules, 2016

**2) Criteria for development of a new Common Bio-medical Waste Treatment and Disposal Facility for a locality or region.**

Prior to allowing any new CBWTF, following criteria or steps may be followed:

- 
- a) Prescribed authority under the BMW Rules, 2016 [i.e., State Pollution Control Board (SPCB) in the respective State or Pollution Control Committee (PCC) in the respective Union Territory Administration] is required to prepare an inventory or review with regard to the bio-medical waste generation at least once in five years in the coverage areas of the existing bio-medical waste treatment and disposal facility. The prescribed authority is also required to extrapolate the coverage-area wise bio-medical waste generation for the next ten years.
  - b) SPCB/PCC is required to conduct gap analysis w.r.to coverage area of the bio-medical waste generation, its projection over a period of next ten years, adequacy of existing treatment capacity of the CBWTF in each coverage area of radius 75 KM, as given in **Annexure-I** and as per methodology for conduct of gap analysis given at **Appendix-I**.

Further, decision may be taken by concerned SPCB/PCC based on gap analysis report to allow new facility or expansion of an existing facility. Adequacy of the existing facility to handle quantum of biomedical waste and/or compliance with the norms prescribed under BMW Rules, 2016 shall also be taken into account.

All the SPCBs and PCCs shall conduct the gap analysis and based on the gap analysis, action plan for development of new CBWTFs is required to be prepared and submitted to MoEF & CC & CPCB within six months' time. In case of States/UTs, where no CBWTF is available, in such a case, SPCB/PCC being prescribed authority under the BMW Rules is required to ensure establishment new facilities. SPCB/PCC may submit the detailed proposal to MoEF & CC/MoH & FW through the respective State Government or UT Administration. Association of HCFs may also be encouraged to develop their own CBWTF following these guidelines. In case, any coverage area requires additional treatment capacity, in such a case, action may be initiated by the prescribed authority for allowing a new CBWTF in that locality based on the gap analysis report without interfering the coverage area of the existing CBWTF.

- c) SPCB/PCC shall identify the coverage area, which require additional treatment facility and bring it to the notice of the concerned department in the business allocation of land assignment in the respective State Government or UT Administration. The department in the business allocation of land assignment shall be responsible for providing suitable site in the identified coverage area for setting up of a CBWTF, in
-

---

consultation with the prescribed authority (i.e., SPCB/PCC), other stakeholders and in accordance with these guidelines issued by CPCB from time to time.

- d) Alternately, a CBWTF may also be allowed to be established on a land procured by an entrepreneur in accordance with the location criteria suggested under these guidelines.
- e) The SPCB/PCC or concerned department in the business allocation of land assignment in the respective State Government or UT Administration may seek expression of interest from the proponents for development of new CBWTF (s) in the identified coverage area. Upon allocation of site to the proponent, the proponent is required to take necessary approvals as required under the Environment (Protection) Act, 1986 for development of the new CBWTF in accordance with these guidelines.
- f) In the absence of expression of interest by any proponent, then SPCB/PCC shall insist health care facilities to form association and to develop its own CBWTF in line with these guidelines or to have captive treatment facilities (Only hilly or remote areas) for ensuring treatment and disposal of generated bio-medical waste as stipulated under the BMWM Rules.
- g) In case of any regulatory action including closure of any existing CBWTF is inevitable, the respective SPCB/PCC may take action under the BMWM Rules including for making alternate arrangement to ensure safe disposal of the bio-medical waste generated from the member health care facilities of such default CBWTF through CBWTF located nearby.
- h) In case of hilly areas considering the geography, only one CBWTF with adequate treatment capacity may be developed covering at least two districts to cater treatment services to the HCFs located in the respective Districts. The selection and allocation of site etc., should be done as per the criteria suggested under these guidelines. The treatment charges to be prescribed by the respective SPCB/PCC in consultation with the State Advisory Committee.

The criteria for development of CBWTFs in any coverage area is also depicted in **Figure 1**.

---

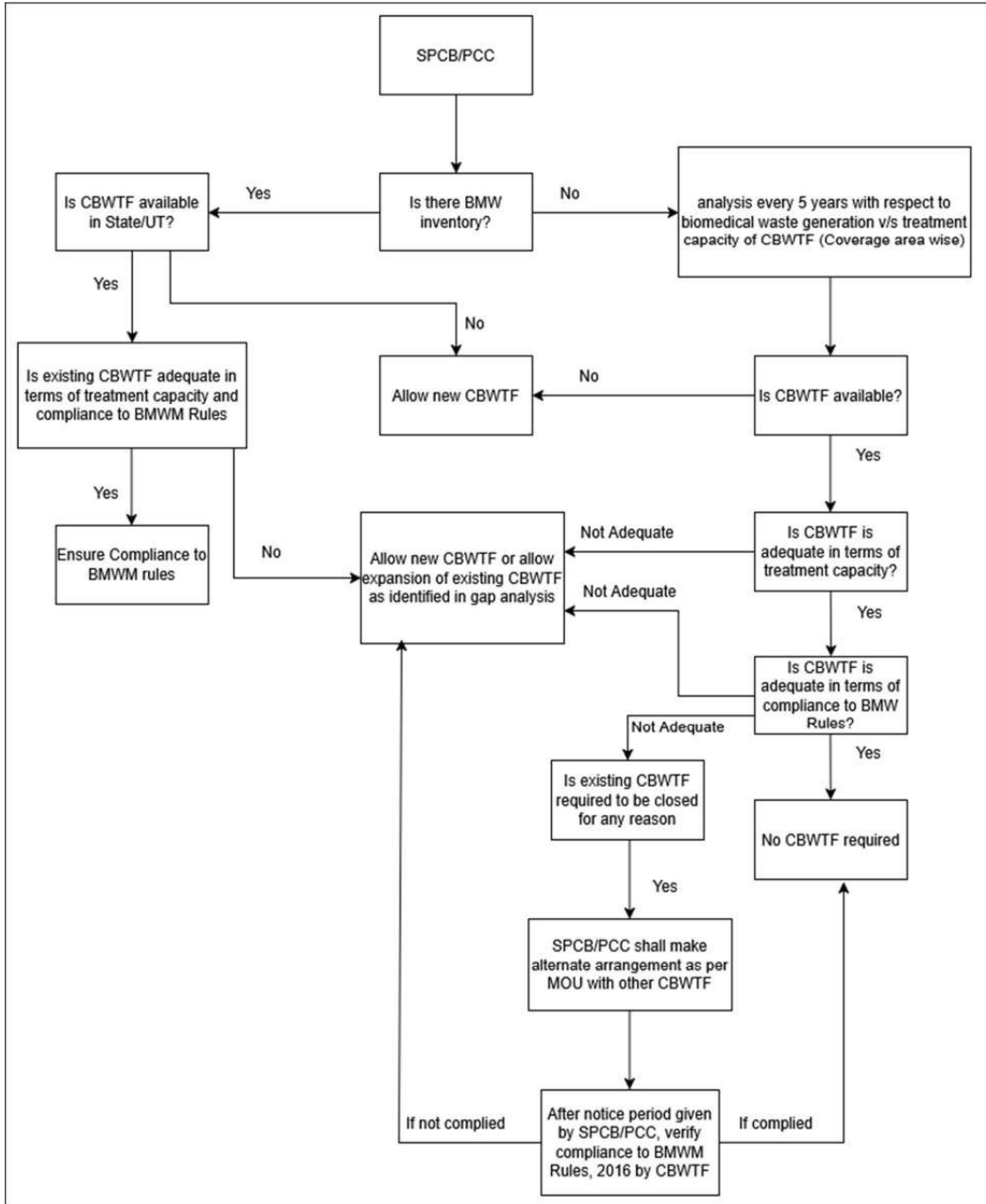

Figure 1. Criteria for Development of a CBWTF in a coverage area

### 3) **Duties of the operator of a common bio-medical waste treatment and disposal facility**

The duties of the operator of a common bio-medical waste treatment and disposal facility (CBWTF) as enunciated under Rule 5 of the Bio-medical Waste Management Rules, 2016 shall be ensured and complied with. All CBWTFs shall also comply w.r.to the residence time as well as emission norms including for Dioxins and Furans for incineration facility as prescribed under BMWM Rules, 2016. In addition to the above, to ensure proper management of bio-medical waste in the respective coverage area, as a mitigation measure, especially in the event of

- (a) a temporary break down (not more than a week) of a CBWTF especially for rectification of the refractory lining of the incineration chambers or change of requisite APCD due to failure; and
- (b) Closure of a CBWTF for violation of the provisions of the BMWM Rules or any other reason.

All CBWTFs are required to submit action plan (in case of closure), to the respective SPCB/PCC, for imposing suitable condition while granting authorisation under the BMWM Rules, 2016. The action plan should include:

- (a) an MoU made with the nearest two CBWTF located within the respective State/UT as alternate arrangement ensuring that the bio-medical waste generated is collected, treated and disposed of within 48 hours as stipulated under the BMWM Rules. In case, if there is no CBWTF located nearby then such CBWTFs should have to install stand by treatment equipment (equal to the existing treatment capacity as per consents granted by the SPCB/PCC), and
- (a) Decontamination plan of the CBWTF for execution of such plan prior to closure of a CBWTF.

### 4) **Applicability of these guidelines**

These guidelines are applicable to all the upcoming or new CBWTFs. In case of the existing CBWTFs, these guidelines shall be applicable

- (a) the existing CBWTFs desires to expand or enhance the existing treatment capacity
- (or)**
- (b) the existing CBWTFs desires to modernize the existing treatment equipment with the new equipment with enhancement in the existing treatment capacity.

---

**5) Environmental laws applicable for commissioning or operation of a CBWTF**

Operation of a CBWTF leads to air emissions as well as waste water generation as in case of an industrial operation. Most common sources of waste water generation in CBWTFs are vehicle washing, floor washing, and scrubbed liquid effluent from air pollution control systems attached with the incinerator/plasma pyrolysis. Incineration as well as DG Set is the general source of air emissions.

**5.1** Any other approvals (such as Land Use /Change in Land Use as applicable) required from the concerned authorities under various laws have to be complied with by the proponent of the CBWTF prior to development of a CBWTF-

**5.2 Consents under Water (Prevention and Control of Pollution) Act, 1974 and Air (Prevention and Control of Pollution) Act, 1981 as well as Authorization under the BMWM Rules, 2016**

The project proponent of the CBWTF is required to obtain 'Consent to Establishment' under Section 25 of the Water (Prevention and Control of Pollution) Act, 1974 and Section 21 of the Air (Prevention and Control of Pollution) Act, 1981, from the respective prescribed authority i.e. SPCB/PCC. Upon installation of the requisite equipment, the CBWTF Operator is also required to obtain authorization under BMWM Rules, 2016 co-terminus with consent to operate under Water (Prevention and Control of Pollution) Act, 1976 & Air (Prevention and Control of Pollution) Act, 1981 from the respective SPCB/PCC prior to commencement of the CBWTF.

**5.3 Environmental Clearance under EIA Notification 2006**

Ministry of Environment, Forest & Climate Change (MoEF & CC), notified amendment to the EIA Notification 2006 and published vide MoEF & CC Notification of S.O. 1142 (E) dated April 17, 2015. According to this notification, the 'bio-medical waste treatment facility' is categorized under the Item 7 (da) in the schedule, requiring 'environmental clearance' from the State Environment Impact Assessment Authority (SEIAA). Therefore, the CBWTF operator is also required to obtain 'Environmental Clearance (EC)' from the respective SEIAA or Ministry of Environment, Forest & Climate Change (MoEF & CC), as the case may be, before any construction work, or preparation of land by the projects management, which include the following:

a) All new projects or activities pertaining to the bio-medical waste treatment facility; and

---

- b) Expansion and modernization with additional treatment capacity of existing bio-medical waste treatment facility (excluding augmentation of incineration facility for compliance to the residence time as well as Dioxins and Furans without enhancing the existing treatment capacity).
- c) Any expansion or modification in the treatment capacity or relocation of the existing CBWTF (requires compliance to the relevant provisions notified under the Environment (Protection) Act, 1986 by the MoEF & CC).

#### 6) Location criteria

In the context of these guidelines, buffer zone represents a separation distance between the source of pollution in CBWTF and the receptor - following the principle that the degree of impact reduces with increased distance. The following parameters may be considered for ascertaining buffer distance on case-to-case basis:

- (i) potential for spread of infection from wastes stored in the premises.
- (ii) applicable standards for pollution control and the relative efficiency of the existing incinerators and emission control systems,
- (iii) potential of fugitive dust emission from incinerators,
- (iv) Quantity and quality of wastewater discharged
- (v) the potential for odour production,
- (vi) the potential for noise pollution,
- (vii) the risk posed to human health due to exposure to emissions from incinerator,
- (viii) the risk of fire and
- (ix) significance of the residual impacts such as bottom ash and fly ash.

As far as possible, the CBWTF shall be located near to its area of operation in order to minimize the transportation distance in waste collection, thus enhancing its operational flexibility as well as for ensuring compliance to the time limit for treatment and disposal of bio-medical waste as stipulated under the BMW Rules (i.e., within 48 hours). Also, the location of the CBWTF should be in conformity to the CRZ Norms and other provisions notified under the Environment (Protection) Act, 1986. The location shall be decided in consultation with the State Pollution Control Board (SPCB)/ Pollution Control Committee (PCC) and SEIAA or MoEF & CC, as the case may be. The location criteria for development of a CBWTF are as follows:

- (a) A CBWTF shall preferably be developed in a notified industrial area without any requirement of buffer zone **(or)**

- 
- (b) A CBWTF can be located at a place reasonably far away from notified residential and sensitive areas and should have a buffer distance of preferably 500 m so that it shall have minimal impact on these areas. In case of non-availability of such a land, the buffer zone distance from the notified residential area may be reduced to less than 500 m by SPCB/PCC without referring the matter to CPCB by prescribing additional control measures such as (i) adoption of best available technologies (BAT) by the proponent of CBWTF; (ii) prescribing stringent standards for operation of the CBWTF by the SPCB/PCC; (iii) adoption of zero liquid discharge by the CBWTF and (iv) in case of any complaints from the public, then CBWTF should prove that the facility is not causing any adverse impact on environment and habitation in the vicinity.
  - (c) The CBWTF can also be developed as an integral part of the Hazardous Waste Treatment Storage and Disposal Facility (TSDF) subject to obtaining of necessary approvals from the authorities concerned including 'environmental clearance' as per Environmental Impact Assessment 2006 and further amendments notified under the Environment (Protection) Act, 1986, provided there is no CBWTF exist within 150 KM distance from the existing TSDF.

## 7) Land requirement

Sufficient land shall be allocated to the CBWTF to provide all requisite systems which include dedicated space for storage of waste (both treated and untreated), waste treatment equipment, vehicle washing bay, vehicle parking space, ETP, incineration ash storage provision, administrative room, space for DG Set etc.,.

- (a) Preferably, a CBWTF shall be set up on a plot size of not less than one acre in all the areas. However, a CBWTF can be developed in adjacent plots but cannot be set up in two or more different plots located in different areas. Separate plots can be permitted only for vehicle parking if located in the close vicinity of the proposed CBWTFs or the existing CBWTFs.
  - (b) In case of upcoming or new CBWTFs (where municipal population is more than 25 lakhs), the land area requirement may be relaxed (but in any case not less than 0.5 acre) by the SPCB/PCC, with additional control measures such as zero liquid discharge, increase in stack height, stringent emission norms, odour control measures or any other measures felt necessary by the prescribed authority on case-to-case basis, only in consultation with SEIAA or MoEF &CC, as the case may be.
-

---

**8) Coverage area of CBWTF**

Suggested coverage area for development of a CBWTF is as follows:

- a) A CBWTF located within the respective State/Union Territory may be allowed to cater to healthcare units situated within a radial distance of 75 kilometers, subject to the condition that the facility possesses adequate treatment capacity to handle the bio-medical waste generated within the said radius. For the purpose of determining adequacy, 90% of the total treatment capacity as authorized by the concerned State Pollution Control Board (SPCB) or Pollution Control Committee (PCC) shall be considered. It shall further be ensured that bio-medical waste generated is collected, treated and disposed of within 48 hours as stipulated under the BMWM Rules.

The concerned SPCB/PCC shall undertake a gap analysis, as per **Appendix-I**, to assess the quantum of bio-medical waste generated vis-à-vis the available treatment capacity of the CBWTF (considering 90% of the authorized treatment capacity). In case the analysis indicates a shortfall in treatment capacity or if the existing CBWTF is found to be non-compliant with the provisions of the Bio-Medical Waste Management Rules, 2016, the SPCB/PCC may consider proposals for establishing a new CBWTF or for expansion of an existing facility, ensuring that bio-medical waste generated is collected, treated and disposed of within 48 hours as stipulated under the BMWM Rules.

- b) In case of hilly areas, considering the geography, only one CBWTF with adequate treatment capacity may be developed covering at least two districts to cater treatment services to the HCFs located in the respective Districts. The selection and allocation of site etc. should be done as per the criteria suggested under these guidelines. The treatment charges to be prescribed by the respective SPCB/PCC in consultation with the State Advisory Committee to be constituted under the BMWM Rules by the respective State Government or UT Administration.

**9) Treatment equipment**

The Common Bio-medical Waste Treatment Facility should treat the bio-medical waste as per BMWM Rules and as per the authorisation granted by the prescribed authority. The CBWTF should have the following treatment facilities:

---

---

a) **Incineration/Plasma Pyrolysis**

**Incineration** is a controlled combustion process where waste is completely oxidized and harmful microorganisms present in it are destroyed/ denatured under high temperature. The guidelines for "Design & Construction Requirements of Bio-medical Waste Incinerators" by CPCB from time to time shall be followed for selecting/or augmenting the incinerator.

**Plasma Pyrolysis** is an alternate to incinerator, Plasma Pyrolysis treatment technology can be installed for disposal of bio-medical waste categories as per BMWM Rules wherein destruction of bio-medical waste is similar to incineration can be achieved. In case of plasma pyrolysis, waste is treated at high temperature under controlled condition to form gases like methane, hydrogen and carbon monoxide which are subjected to combustion (oxidation) in secondary chamber. In the plasma pyrolysis process waste is converted into small clinker which can be disposed in secured landfills.

b) **Autoclaving/Hydroclaving/Microwaving**

- (i) **Autoclaving** is a low-heat thermal process where steam is brought into direct contact with waste in a controlled manner and for sufficient duration to disinfect the wastes as stipulated under the Bio-medical Waste Management Rules. For ease and safety in operation, the system should be horizontal type and exclusively designed for treatment of bio-medical waste. For optimum results, pre-vacuum based system be preferred against the gravity type system. It shall have tamper-proof control panel with efficient display and recording devices for recording critical parameters such as time, temperature, pressure, date and batch number etc. as required under the BMWM Rules.
- (ii) **Hydroclaving** is similar to that of autoclaving except that the waste is subjected to indirect heating by applying steam in the outer jacket. The waste is continuously tumbled in the chamber during the process.
- (iii) **Microwaving:** In microwaving, microbial inactivation occurs as a result of the thermal effect of electromagnetic radiation spectrum lying between the frequencies 300 and 300,000MHz. Microwave heating is an inter-molecular heating process. The heating occurs inside the waste material in the presence of steam.
-

- 
- c) Chemical disinfection:** Though chemical disinfection or alternates as stipulated under the BMWM Rules is also an option for treatment of certain categories of bio-medical waste such as glass waste but looking at the volume of waste to be disinfected at the CBWTF and the pollution load associated with the use of chemical disinfectants, the chemical disinfection for treatment of bio-medical waste as part of a CBWTF may be used sparingly or avoided as far as possible.
- d) Dry heat sterilization:** This is the additional option for treatment of waste sharps as stipulated under the BMWM Rules. In this method, waste sharps are treated using dry heat (hot air) at a temperature not less than 185°C, at least for a residence period of 150 minutes in each cycle (with sterilization period of 90 minutes).
- e) Shredder:** Shredding is a process by which waste are de-shaped or cut into smaller pieces so as to make the wastes unrecognizable. It helps in prevention of reuse of bio-medical waste and also acts as identifier that the wastes have been disinfected and are safe to dispose of. A shredder to be used for shredding bio-medical waste shall confirm to the following minimum requirements:
- (i) The shredder for bio-medical waste shall be of robust design with minimum maintenance requirement;
  - (ii) The shredder should be properly designed and covered to avoid spillage and dust generation. It should be designed such that it has minimum manual handling;
  - (iii) The hopper and cutting chamber of the shredder should be so designed to accommodate the waste bag full of bio-medical waste;
  - (iv) The shredder blade should be highly resistant and should be able to shred waste sharps, syringes, scalpels, blades, plastics, catheters, intravenous sets/ bottles, blood bags, gloves, bandages etc. It should be able to handle/ shred wet waste, especially after microwave/ autoclave/hydroclave;
  - (v) The shredder blade shall be of non-corrosive and hardened steel;
  - (vi) The shredder should be so designed and mounted so as not to generate dust, high noise & vibration;
  - (vii) If hopper lid or door of collection box is opened, the shredder should stop automatically for safety of operator;
  - (viii) In case of shock-loading (non-shreddable material in the hopper), there should be a mechanism to automatically stop the shredder to avoid any emergency/accident;
-

- (ix) In case of overload or jamming, the shredder should have mechanism of reverse motion of shaft to avoid any emergency/accident;
- (x) The motor shall be connected to the shredder shaft through a gear mechanism, to ensure low rpm and safety;
- (xi) The unit shall be suitably designed for operator safety, mechanical as well as electrical;
- (xii) The shredder should have low rotational speed (maximum 50 rpm). This will ensure better gripping and cutting of the bio-medical waste;
- (xiii) The discharge height (from discharge point to ground level) shall be sufficient (minimum 3 feet) to accommodate the containers for collection of shredded material. This would avoid spillage of shredded material;
- (xiv) The minimum capacity of the motor attached with the shredder shall be 3 KW for 50 Kg/hr, 5 KW for 100 kg/hr & 7.5 KW for 200 Kg/hr and shall be three phase induction motor. This will ensure efficient cutting of the bio-medical wastes as prescribed in the Bio-medical Waste Management Rules; and
- (xv) The shredder also should be fitted with separate 'energy meter' for recording total energy consumed for operation of this equipment.

**g) *Sharp pit/ Encapsulation:*** A sharp pit or a facility for sharp encapsulation in a metal container or cement concrete shall be provided for treated sharps (*i.e., treatment by autoclaving or dry heat sterilization followed by shredding or mutilation*). An option may also be worked out for recovery of metal from treated and shredded waste sharps within the CBWTF or iron foundries having consent to operate from the SPCBs/PCCs and located nearby, as per the conditions imposed in authorization granted under BMWM Rules by the SPCB/PCC.

A sharp pit may be of circular or rectangular shape and shall be dug and lined with cement plastered brick masonry or concrete rings. The pit should be covered with a heavy concrete slab with a provision of galvanized steel pipe projecting about 1.5 meters above the slab, with an internal diameter of up to 50 mm or 1.5 times the length of vials, whichever is more. The top opening of the steel pipe shall have a provision of locking after the treated waste sharps are disposed into the sharp pit. When the pit is full, it can be sealed completely, after another pit is prepared. In case of high water table regions (*i.e., where water table is less than 6 metres beneath the bottom of the sharp pit*), a tank with above mentioned arrangements shall be made above the ground.

- 
- h) *Deep burial:*** SPCB/PCC should not allow the 'deep burial' of bio-medical waste as a part of CBWTF.
- i) *Non-burn technology:*** Non-incineration technologies for disposal of bio-medical waste are adopted in some of the developed countries. Non-incineration technology comprises of shredding and disinfection by autoclaving/microwaving or chemical treatment. The treated waste can be disposed along with municipal solid waste in sanitary landfills or through waste to energy plants. Such option can also be adopted in places where the sanitary landfill or waste to energy plant for disposal of municipal solid waste is available. Such technology is permitted only after prior approval of MoEF & CC and only after obtaining authorization under the BMWM Rules from the respective SPCB/PCC for the purpose of carrying out trial runs for assessment of efficacy of the treatment equipment.
- j) *Vehicle/Containers washing facility:*** Every time a vehicle is unloaded, the vehicle and empty waste containers shall be washed properly and disinfected. Washing can be carried out in an open area but on an impermeable surface and liquid effluent so generated shall be conveyed and treated in an effluent treatment plant. The impermeable area shall be of appropriate size so as to avoid spillage of liquid during washing.
- k) *Effluent Treatment Plant:*** A suitable Effluent Treatment Plant (ETP) shall be installed to ensure that liquid effluent generated during the process of washing containers, vehicles, floors etc. is treated and reused after treatment. Proper treatment of waste water shall be ensured in case of zero discharge by recirculation of treated waste water for scrubbing. ETP may have treatment unit operations comprising collection tank, O & G trap, chemical dosing cum mixing (Flash and slow), coagulation chamber, primary settling tank (s), biological treatment process, secondary settling tank, pressure filter and activated carbon filter, pH Correction tank (wherever recirculation of treated water is practiced) so as to comply with the liquid discharge standards stipulated under the Bio-medical Waste Management Rules, 2016. ETP may also have the following provisions:
- (i) separate 'energy meter' so as to know total consumption of electricity for operation of the machinery attached with the ETP.
-

- (ii) pH meter so as to know pH level of treated water as well as pH level of treated water used for recirculated or recycling in APCD attached with the incinerator or any utility within the CBWTF.
- (iii) A 'magnetic flow meter' should also be fitted at all the water supply extraction points of the CBWTF as well as the outlet to know the total wastewater treated for further end use or discharge in compliance to the BMWM Rules.
- (iv) Provision of 'press filter' to reduce the moisture content of the ETP Sludge or it may be dried in 'sludge drying bed'. After removal of moisture content or drying, same need to be disposed of in an environmentally sound manner depending upon the hazardous constituents present in it as per Hazardous and Other Waste (Management and Transboundary Movement) Rules, 2016. In case, ETP sludge contains metal contents within the prescribed limits as per Hazardous & Other Waste (Management & Transboundary Movement) Rules, 2016, such ETP sludge shall be given to CBWTF for incineration or to hazardous waste treatment, storage and disposal facility (TSDF) for disposal in secured landfill.

**Note:**

- a) If any CBWTF desires to adopt any other technology other than referred under Schedule –I of the BMWM Rules, may adopt new technology only with the prior approval from MoEF & CC and is also required to obtain authorization under the BMWM Rules from the respective SPCB/PCC for carrying out trial run for assessment of efficacy of the new technology.
- b) All the treatment equipment should be operated and complied with the norms as stipulated under Schedule II of the Bio-medical Waste Management Rules, 2016 published by MoEF & CC vide GSR 343 (E) dated 28<sup>th</sup> March, 2016.
- c) Incinerator / Plasma Pyrolysis/ Autoclaving/Microwaving/ Hydroclaving/ Shredder/ Dry Heat Sterilization/ ETP should be fitted with separate 'energy meter' for recording total energy consumed for operation of these equipment.
- d) In the event of temporary shutdown (not more than a week) due to any operational problems in the treatment equipment (such as restoration of refractory lining or maintenance or repairs in APCD), to ensure bio-medical waste collected from the member health care facilities is treated within the time limit as stipulated under the BMWM Rules, all CBWTF operators should also be provided with stand by treatment equipment especially incinerator/plasma pyrolysis/autoclave (or) alternately MoU made with the nearby CBWTF (located within the State/UT) shall be submitted to the respective SPCB/PCC, by all the existing CBWTF operators (whereas the upcoming facilities have to make such arrangement prior to commencement of the facility) so as to include such condition while granting authorisation under the BMWM Rules, 2016 to the concerned CBWTF operators (vice-versa).

---

**(10) Infrastructure set up**

The CBWTF shall have enough space within it to install required treatment equipment, untreated and treated waste storage area, vehicle-parking, vehicle and containers washing area, Effluent Treatment Plant (ETP), administration room or staff room etc. The required area for CBWTF would depend upon the projected amount of bio-medical waste to be handled by it. A CBWTF shall have the following infrastructure:

**a) Treatment equipment room**

A separate housing may be provided for each treatment equipment at the CBWTF such as incinerator room, autoclave room, microwave room etc., as applicable. Each room shall have well-designed roof and walls. Such room shall be well ventilated and easy to wash. The floor and interior finishing of the room shall be such that chances of sticking/harboring of microorganisms are minimized. This can be attained by providing smooth & fine floor and wall surfaces (to a height of 2 meter from floor) preferably of tiles. The number of joints in such surfaces shall be minimal. The equipment room shall also have a separate cabin, to supervise the operation of the equipment and to record the waste handling and equipment operational data attached to each equipment room. There shall be two waste storage rooms, one for storage of untreated waste and another for treated waste and may be located at a distance from each other. The storage room shall have provisions similar to that of equipment room being well-ventilated with easy to wash floors & walls, smooth and fine surfaces etc. All the treatment equipment rooms and waste storage rooms should be provided with 'fly catcher/killing device'. The room shall be washed and cleaned with a suitable disinfectant every day.

**b) Main waste storage space**

Separate space shall be provided near the entry point of the CBWTF to unload and store all biomedical wastes that have been transported to the CBWTF by its own transportation vehicle. The size of the room shall be adequate to store all wastes transported to the CBWTF. The front portion of the room shall be utilized for unloading the wastes from the vehicle and back or side portion shall be utilized for shifting the wastes to the respective treatment equipment. In the front portion of the room where transportation vehicle is parked for unloading, the floor shall be made impermeable so that any liquid spillage during unloading does not percolates into the ground. The liquid generated during handling of wastes and washing, shall be diverted to the inlet

---

---

of effluent treatment plant (ETP). In the main storage room, wastes shall be stacked with clear distinction as per the color coding of the containers by providing partitions. From here, the colored containers may be sent to the respective treatment equipment by using suitable closed type of conveyance (trolley etc.). The main storage room too shall have provisions similar to that of equipment room such as roofing, well ventilated, easy to wash floors & walls, smooth and fine surfaces etc.

Apart from the above, a CBWTF should have separate storage provision for storage of mercury bearing waste collected from the member health care facilities as per the procedure given in CPCB guidelines. Mercury storage provision should be provided as per the guidelines issued by CPCB (refer [www.cpcb.nic.in](http://www.cpcb.nic.in)). The capacity of the mercury storage provision should be maximum of 90 days and by which the collected mercury bearing waste shall have to be disposed of through a TSDF located nearby following the manifest as per Hazardous and Other Waste (Management and Transboundary Movement) Rules, 2016. The charges for collection and disposal of mercury bearing waste shall be collected by the CBWTF from the respective member HCF.

**c) Treated waste storage room**

Separate space should be provided to store the wastes treated in different treatment units. The wastes shall be stored in separate group as per the disposal options. Other provisions in the room shall be similar to the main storage room. Waste such as incineration ash/vitrified ash generated in the process of incineration/plasma pyrolysis respectively shall be stored safely in a separate area under the shed so as to avoid entry of rain water during the monsoon and for easy collection. In case, incineration ash/ vitrified ash is found to be hazardous waste in nature same should be disposed of through any authorized TSDF operator located nearby following the manifest as per Hazardous and Other Waste (Management and Transboundary Movement) Rules, 2016. In case of a State/UT where TSDF is not available, all the CBWTF operators have to store incineration ash safely as per these guidelines.

**d) Administrative Room**

This room shall be utilized for general administration, record keeping, billing etc.

**e) Generator set**

---

---

CBWTF shall have a generator set of adequate capacity as standby arrangement for power, with sufficient capacity to run the treatment equipment during the failure of power supply. The generator set shall comply with the necessary requirement as per DG Set norms notified under the Environment (Protection) Act, 1986.

**f) Continuous emission monitoring system (CEMS)**

Monitoring provision for continuous monitoring of the incinerator/plasma pyrolysis stack emission shall be installed by the CBWTF operators for the parameters as stipulated by the respective SPCB/PCC as per the authorisation granted under the BMWM Rules, 2016. Other-wise, at present, all the existing CBWTF operators are required to carry out stack emission monitored using continuous emission monitoring system for the flue gas parameters such as CO<sub>2</sub>, O<sub>2</sub>, CO as well as primary & secondary chamber temperatures, and records maintained. The continuous emission monitoring system for stack emission should be installed as per the guidelines issued by SPCB/PCC/CPCB. Also, the real time continuous stack emission monitoring data is also required to be transmitted to the servers of the respective SPCB/PCC as well as CPCB, by all the existing CBWTF operators

**g) Vehicle Parking**

Provision for parking shall be made within the confines of the site for parking of required number of vehicles, loading and unloading of the vehicles meant for transporting waste to and from the facility, etc. In case of a CBWTF with space constraints, multi-storey parking or a separate provision may be allowed only for parking of vehicles.

**h) Display and sign board**

An identification board (Display) of durable material and finish shall be displayed at the entrance to the facility. This shall clearly display the name of the facility, owner name, address and telephone number of the operator and the prescribed authority, no. of hours of operation & operational hours, telephone numbers of the personnel to be contacted in the event of an emergency, validity period of authorization as well as total daily waste treated and disposed. Also, sign boards should be provided at all the salient points (untreated waste storage area, treatment equipment, treated waste storage area, ETP, firefighting equipment) within the facility.

---

---

**i) Washing Room**

A washing room shall be provided for eye washing/hand washing/ bathing etc. for the workers.

**j) Site Security**

High walls, fencing and guarded gates shall be provided at the facility to prevent unauthorized access to the site by humans and livestock.

**k) Fire safety**

Fire safety equipment such as sand buckets and fire extinguishers should be provided at all the salient points of the CBWTF including at the diesel storage areas, diesel tanks connected with the incinerator etc. Fire alarm also should be provided within the CBWTF to prompt the workers in the event of any fire hazard. Workers should also be trained in First Aid administration.

**l) First Aid Box**

First Aid Box with necessary provisions need to be provided at all the salient points within the facility.

**m) Green Belt**

The open area available within the CBWTF shall be developed into green belt.

**n) Website:**

All CBWTFs shall develop own website and the upcoming CBWTF shall develop the website prior to the commencement of the facility. The website should be uploaded with relevant information periodically (on monthly basis) especially as detailed below:

- (i) A copy of the Environmental Clearance obtained;
  - (ii) Copies of the Consents under the Water (Prevention and Control of Pollution) Act, 1974 and Air (Prevention and Control of Pollution) Act, 1981 as well as the Authorisation under the BMWM Rules obtained from the SPCB/PCC;
-

- 
- (iii) List of all the member Health Care Facilities with complete address, bedded or non-bedded HCFs, no. of beds, bar code, category-wise average bio-medical waste generation in kg/annum;
  - (iv) Charges levied on the member Health Care Facilities (HCFs) for treatment and disposal of bio-medical waste;
  - (v) Vehicles connected with a provision of GPS as per BMWM Rules and Vehicle-wise route chart for collection, transportation of bio-medical waste from the member HCFs;
  - (vi) Real time continuous online stack emission monitoring data;
  - (vii) Monthly details of total waste collected from the member HCFs, total waste treated, and treated recyclable plastic waste or glass waste sold to the parties and final mode of disposal of incineration ash;
  - (viii) A copy of the annual report submitted to the respective SPCB/PCC;
  - (ix) Monitoring results of the stack emissions, treated wastewater and incineration ash, as per the frequency stipulated under the BMWM Rules;
  - (x) List of HCFs ( located within the coverage area) with complete address which have not taken membership of the CBWTF for disposal of Bio-medical waste;
  - (xi) Contact person, contact telephone number and e-mail addresses of the facility; and.
  - (xii) Provision to have access to the SPCB/PCC/CPCB/MoEF & CC/MoH & FW especially on GPS, online monitoring system and the data.

Besides the provisions suggested in the earlier paras, following important provisions should also be made in a CBWTF:

- (i) A telephone shall be provided and maintained at the facility.
  - (ii) A First Aid Box shall be provided and maintained at the CBWTDF.
  - (iii) Proper lighting shall be provided at the facility.
  - (iv) Proper care shall be taken to keep the facility and surroundings free from odors.
  - (v) Measures shall be implemented to control pests and insects at the site.
  - (vi) Measures shall be implemented to control the escape of litter from the site.
  - (vii) Necessary provision shall be made to prevent and control noise generated, if any, due to the activities at the site.
  - (viii) Necessary protective gear for the waste handlers shall be provided.
  - (ix) Immunization to all the workers of CBWTF against all the diseases including especially Tetanus and Hepatitis -B as stipulated under the BMWM Rules.
  - (x) Workers should have provisions such as washing, toilet, and suitable place for eating.
-

- 
- (xi) Workers should also be provided with N-95 mask besides other PPEs such as hand gloves, gumboots, goggles etc.

Every CBWTF operator shall submit a work-plan to the Prescribed Authority. The work-plan should include the details of facilities at the CBWTF, collection, transportation & storage of the bio-medical wastes, operational details etc.

## 11) Record keeping

Maintenance of records for all operations carried out at the CBWTF is very important to monitor overall operation of the CBWTF. It also helps in submission of the required information to be submitted to the 'Prescribed Authority' by 30<sup>th</sup> June of every year as per the format prescribed under the BMWM Rules or provided by the SPCB/PCC. A well-maintained record of all the activities at the CBWTF also enables the facility operator to produce all information of the activities on demand of the concerned prescribed authority. The record should include all information relating to each activity at the CBWTF site as per BMWM Rules which include accidents occurred (spills, injury, fire accident) and the measures taken and also, however, minimum requirement is outlined below:

### a) Records of waste movements

Daily records shall be maintained for the waste accepted and treated waste removed from the site. This record shall include the following minimum details:

- (i) **Waste accepted:** -Records on day-to-day basis (as per the format given at **Annexure-II**) shall be maintained with respect to the waste collection date, name of the healthcare unit with bar code, waste category as per BMWM Rules, category-wise quantity of waste accepted, vehicle registration number used for collection of bio-medical waste from member health care facilities, time at which waste collected from member HCFs, name of the vehicle driver and his signature and waste receiving date & time (at CBWTF site). Similar information to be acknowledged to the member health care facility by the CBWTF operator on daily basis.
- (ii) **Treated waste to be disposed :-** Date, treated waste type, Quantity, vehicle number, disposal as stipulated under BMWM Rules.
-

**b) Logbook for the treatment equipment**

A logbook shall be maintained for each treatment equipment installed at the site and shall include the following:

- (i) The weight of each batch.
- (ii) The categories of waste as per the Rules.
- (iii) The time, date and duration of each treatment cycle and total hours of operations.
- (iv) The complete details of all operational parameters during each cycle.

Log book to be maintained for operating the incinerator/plasma pyrolysis as well as the autoclave as per the formats given at **Annexure -III.**

**c) Monitoring and reporting of operations in the CBWTF:**

The monitoring of the key operating parameters of treatment equipment provides several benefits. First, monitoring provides the operator with information needed to make decisions on necessary combustion control adjustments. Second, properly maintained monitoring records can provide useful information for identifying operating trends and potential maintenance problems. Following are the suggested parameters for monitoring of the treatment equipment

**(i) Monitoring of operating parameters of the incinerator/plasma pyrolysis:**

Following operating parameters can be monitored in case of incinerator/plasma pyrolysis:

- Waste charge rate.
- Combustion gas temperature in primary and secondary chamber as well as the temperature of the stack exit gas (flue gas).
- Condition of the draft (negative draft in primary chamber).
- Combustion gas oxygen level in primary and secondary chamber as well as stack exit gas.
- Air flow rate through the incinerator/plasma pyrolysis.
- Carbon-Di-Oxide (CO<sub>2</sub>), Oxygen (O<sub>2</sub>) and Carbon Monoxide (CO) level in the flue gas.

- Quantity of auxiliary fuel usage as well as the power consumption (in every batch).
- Pressure drop in the primary chamber and APCD attached with the incinerator/plasma pyrolysis and
- Bottom ash or slag quality (for Total Organic Carbon (TOC) as well as loss on ignition and the hazardous constituents (at least once in a quarter).

**(ii) Monitoring of operating parameters of the Autoclave:** Following operating parameters can be monitored during the sterilization using autoclave:

- Time at which sterilization started and time at which sterilization completed.
- Temperature conditions maintained throughout the sterilization
- Conditions of pressure maintained throughout the sterilization
- Duration of sterilization
- Validation test results

Records concerning the above parameters need to be maintained and checked periodically for taking remedial measures during the operation of the incinerator or plasma pyrolysis or autoclave. In case of other treatment processes, the operational conditions as well as the efficacy tests to be complied with as per the standards prescribed under the BMWM Rules.

**(iii) Frequency of monitoring:**

The CBWTF operator shall carry out following tests through a NABL approved laboratory or a laboratory approved under the Environment (Protection) Act, 1986, as per the frequency stipulated under the BMWM Rules or as prescribed by the SPCB/PCC and record of such analysis results shall be maintained and submitted to the prescribed authority (SPCB/PCC), as suggested below:

- **Liquid effluent:** Parameters such as pH, Suspended Solids, Oil & Grease, BOD, COD, Bio-assay for liquid effluent being discharged from the CBWTF be monitored as per the Consent conditions or once in a quarter and such records maintained and submitted to SPCB/PCC.
- **Stack emission monitoring:**

In case of the BMW incinerators, the Stack Emission shall be monitored (under optimum capacity) for parameters such as Particulate Matter, HCl, NO<sub>x</sub>, Hg & compounds and combustion efficiency once in three months as required under schedule II of the Bio-medical Waste Management Rules 2016 (All monitored values shall be corrected to 11% Oxygen on dry basis). In case of dioxins and furans, monitoring should be done once in a year (monitored values shall be corrected to 11% Oxygen on dry basis).

➤ **Validation test of autoclave/microwave/chemical treatment/Dry heat sterilization:**

Suggested validation test for treatment of bio-medical waste by autoclave/microwave/chemical treatment/Dry heat sterilization is given in **Table 1.**

**Table 1: Suggested validation test for treatment of bio-medical waste by autoclave/microwave/chemical treatment/Dry heat sterilization**

S. No	Type of equipment used for treatment of bio-medical waste	Type of Validation Test	Frequency
(i)	Autoclave	(i) biological indicator strips or vials Geobacillus stearothermophilus spores with at least 1X10 <sup>6</sup> spores),	once in three months
		(ii) chemical indicator strip or tape	each batch of waste treated
(ii)	Microwave	Bacillus atrophaeus spores using vials or spore strips with at least 1 x 10 <sup>4</sup> spores per detachable strip	Recommended: once in three months
(iii)	Chemical treatment followed by shredding	Bacillus Subtilis (ATCC 19659)- 4 Log <sub>10</sub> reduction or greater	Once in a week
(iv)	Dry heat sterilization	consistently kill the biological indicator Geobacillus Stearothermophilus or	Once in three months

S. No	Type of equipment used for treatment of bio-medical waste	Type of Validation Test	Frequency
		Bacillus Atropheaus spores using vials with at least 6 log <sub>10</sub> spores per ml.	
		A chemical indicator strip or tape	Once in a week

**d) Site Records:**

Site records shall include the following:

- (i) All the approvals obtained from other concerned departments other than the prescribed authority;
- (ii) Details of construction or engineering works;
- (iii) Maintenance schedule, breakdowns/trouble shootings and remedial actions;
- (iv) Emergencies;
- (v) Incidents of unacceptable waste received and the action taken; and
- (vi) Details of site inspections by the officials of the regulatory authorities, purpose of visits with date and necessary actions initiated on the observations.

Daily, monthly and annual summary records of all the above shall be maintained and made available at the site for inspection and same submitted whenever required by an authorized official of the concerned regulatory authorities.

**12) Collection and transportation of bio-medical waste**

The collection and transportation of bio-medical waste shall be carried out in a manner so as to prevent any possible hazard to human health and environment. Collection and transportation are the two operations where the chances of segregated bio-medical waste coming in contact with the public, rag pickers, animals/birds, etc. are high. Therefore, all care shall be taken to ensure that the segregated bio-medical waste handed over by the healthcare units reach CBWTF without any damage, spillage or unauthorized access by public, animals etc. A responsible person from the CBWTF operator shall always accompany the vehicle to supervise the collection and transportation of bio-medical waste. Also, the private transport vehicles should not be

---

authorised by the SPCBs/PCCs only for transportation of the Bio-medical Waste. The CBWTF operator should be made responsible for collection and transportation of bio-medical waste.

**a) Collection of bio-medical waste:**

Generator of the bio-medical waste is responsible for providing segregated waste in accordance with the provisions of the Bio-medical Waste Management Rules, 2016, to the CBWTF operator. Dedicated temporary storage at healthcare unit shall be designated. The coloured bags handed over by the healthcare units shall be collected in similar coloured containers with proper cover. Each bag shall be labeled as per Schedule IV of the Bio-medical Waste Management Rules as well as with bar coding system (to be complied by the occupier or operator of a CBWTF as per BMWM Rules) so that at any time, the healthcare units can be traced back that are not segregating the bio-medical wastes as per BMWM Rules. The coloured containers should be strong enough to withstand any possible damage that may occur during loading, transportation or unloading of such containers. These containers shall also be labeled as per Schedule IV of the Rules. Sharps shall be collected in puncture resistant container. The person responsible for collection of bio-medical wastes shall also carry a register with him to maintain the records such as name of the healthcare unit, the type and quantity of waste received, time at which waste collected from the member HCF, signature of the authorised person from the healthcare unit etc. During transportation, the containers should be covered in order to prevent exposure of public to odours and contamination.

**(b) Transportation of the collected bio-medical waste to the CBWTF:**

All the vehicles used by the CBWTF operator shall not be sub-letted or contract vehicles should not be used by the CBWTF operator. All the vehicles owned by the CBWTF operator and intended only for collection of bio-medical waste from the member health care facilities should be registered under the Motor Vehicle Act with the respective RTO/Transport Department and such vehicle numbers should also be registered with the respective SPCB/PCC for the purpose of collection of bio-medical waste from the member health care facilities. The bio-medical waste collected in designated coloured containers shall be transported to the CBWTF in a fully covered vehicle. Such vehicle shall be dedicated for transportation of bio-medical waste only. Depending upon the volume of the wastes to be transported, the vehicle may be a

---

---

two or three-wheeler, light motor vehicle or heavy duty vehicle. In either case, the vehicle must possess the following:

- (i) Transportation vehicle shall be fitted with GPS to track the movement of the vehicle.
  - (ii) Separate cabins shall be provided for driver/staff as well as for placing the designated colour coded bio-medical waste containers.
  - (iii) Two wheeler registered under the Motor Vehicle Act shall be permitted for collection of bio-medical waste only from the clinics or dispensaries located in places where the lanes are narrow and not easily accessible to four wheeler vehicles. Such two wheeler vehicle (s) should have a provision of a suitable fixed waste collection box marked with bio-hazard symbol, contact details, proper lid, emergency spill collection procedure, first aid box and manifest record in accordance with the BMWM Rules
  - (iv) The base of the waste cabin shall be leak proof to avoid pilferage of liquid during transportation.
  - (v) The waste cabin may be designed for storing waste containers in tiers and also should be provided with a lighting provision.
  - (vi) The waste cabin shall be so designed that it is easy to wash and disinfect.
  - (vii) The inner surface of the waste cabin shall be made of smooth surface to minimize water retention.
  - (viii) The waste cabin shall have provisions for sufficient openings in the rear and/or sides so that waste containers can be easily loaded and unloaded.
  - (ix) The vehicles used for the purpose of collection and transportation of bio-medical waste must be labelled with the bio-hazard symbol (as per Schedule IV of the BMWM Rules, 2016) in red/black colour and should display the name, address, and contact number of the CBWTF operator in green colour. CBWTF authorized by ("*Name of SPCB/PCC*") shall also be mentioned below name,
-

---

address and contact number of the CBWTF operator in green colour, as given in **Annexure-VII**.

- (x) All the existing vehicles used for the purpose of collection and transportation of biomedical waste shall be labelled with the bio-hazard symbol and shall display the name, address, and contact number of the CBWTF operator on white background (as given in **Annexure-VII**). Further, vehicles registered with the respective SPCB/PCC for the purpose of collection and transportation of biomedical waste after June, 2025 shall be white in colour.
- (xi) Bio-hazard symbol size and font size shall be in minimum proportion of 12:3 and 12:1, respectively, with respect to body height of the vehicle used for transportation of biomedical waste. For Example: If body height is 6 feet i.e. 72" then minimum font size will 6" and minimum size of bio-hazard symbol will be 18" as given in **Annexure-VII**.
- (xii) The vehicle driver should carry always valid registration of the vehicle obtained from the concerned transport authority and also carry valid 'pollution under control certificate' issued by the authorized certificate issuing agency.

Depending upon the area to be covered under the CBWTF, the route of transportation shall be worked out. The transportation routes of the vehicle shall be designed for optimum travel distance and to cover all member healthcare units of the CBWTF. The CBWTF operator should ensure online and real time tracking & monitoring provisions (GPS provision) should be given access with passwords to the SPCB/PCC and CPCB to cross check the movement of the transportation vehicles on any time by the SPCB/PCC/CPCB. As far as possible, the transportation shall be carried out during non-peak traffic hours. If the area to be covered is very large, a satellite station may be established to store the bio-medical waste collected from the adjoining areas. The wastes so stored at satellite station may then be transported to the CBWTF in a big vehicle. It shall be ensured that the total time taken from generation of bio-medical waste to its treatment, which also includes collection and transportation time, shall not exceed 48 hours.

---

**13) Disposal option of solid waste generated from the CBWTF**

Treated plastic waste, incineration ash, treated waste sharps and glass waste, Oil & Grease waste and ETP sludge are generally generated from the CBWTF from the treatment systems such as autoclaving/microwaving, incineration, chemical disinfection and effluent treatment plant respectively. The treated bio-medical waste shall be disposed as per the options suggested in the **Table 2** given below:

**Table 2: Suggested Disposal option of solid waste generated from the CBWTF**

Sl. No.	Treated Waste Category	Suggested Treatment and Disposal Options
1.	Plastic wastes	Plastic waste should not be sent to landfill sites. Plastic waste after disinfection and shredding, is required to be (i) sent to registered or authorized recyclers (or) (ii) for energy recovery (or) (iii) diesel or fuel oil recovery (or) (iv) for road making, whichever is possible.
2.	Disinfected Sharps (including needles and syringes)	Treatment by Autoclaving or Dry Heat Sterilization followed by shredding or mutilation or combination of shredding cum autoclaving. Treated sharps need to be disposed of (i) by encapsulation in metal container or cements concrete; (or) (ii) sent for final disposal to iron foundries (having consent to operate from the SPCBs/PCCs) (or) (iii) Disposal in sanitary landfill; (or) (iv) Disposal in designated concrete waste sharp pit.
3.	Incineration ash	Incineration ash from incineration of any bio-medical waste shall be disposed through hazardous waste treatment, storage and disposal facility (TSDF), if toxic or hazardous constituents are present beyond the prescribed limits as given in Schedule –II of the Hazardous and Other Waste Management & Transboundary Movement Rules or as revised from time to time.
4.	Other treated solid wastes like Glass waste	Disinfection (by soaking the washed glass waste after cleaning with detergent and Sodium Hypochlorite

Sl. No.	Treated Waste Category	Suggested Treatment and Disposal Options
		treatment) or through autoclaving or microwaving or hydroplaning and then sent for recycling.
5.	Oil & Grease	By Incineration
6.	ETP Sludge	After drying in sludge drying beds or removal of moisture content using 'Filter Press' and such ETP sludge shall be given to CBWTF for incineration or to the hazardous waste treatment, storage and disposal facility (HWTSDF) for disposal in Secured Landfill
7.	Hazardous Waste	Disposal through a TSDF located nearby following the manifest as per the Hazardous and Other Waste (Management & Transboundary Movement) Rules, 2016

#### 14) Cost to be charged by the CBWTF Operator for the Health Care Facilities

Cost to be charged from the healthcare facilities plays an important role in financial viability and sustainable operation of a CBWTF project, for providing the best treatment services to the Health Care Units and for ensuring compliance to the BMWM Rules. The cost shall be so worked out that neither it becomes a monopoly of the CBWTF operator nor the interest of the CBWTF operator is overlooked. It is recommended that cost to be charged from the healthcare units, depending on the size, no, of beds and the distance from the location of the CBWTF and same shall be worked out in consultation with the concerned SPCB/PCC and the local Medical Association, keeping in view the following options:

- (a) In case of non-bedded health care units, fixed charges depending on the average quantity of waste generation per day, in case of the nursing homes/clinics/sample collection Centres /Dental HCentres, dispensary, pathological laboratory, blood banks, and other non-bedded hospitals irrespective of their system of medicine including ayush hospitals.
- (b) In case of bedded hospitals, fixed charges per bed per day basis and based on the no. of beds for which consents under the Water Act, 1974/Air Act, 1981 and authorization granted under the BMWM Rules, by the prescribed authority

**Note:**

- (i) *Rates are required to be revised once in a year based on the Wholesale Price Index (WPI Index) or Consumer Price Index (CPI Index) (considering the prevailing market price especially in respect of the labour expenses, diesel prices, electricity, operating cost etc.,), by the State Advisory Committee in consultation with the concerned SPCB/PCC, local Medical Association and the representatives of the CBWTF Association*
- (ii) *The Health Care Facilities are required to ensure timely payments to the CBWTFs for ensuring timely treatment services in compliance to the BMWM Rules as well as agreement made with the concerned CBWTF Operator.*

**15) Check list for development of CBWTF**

The criteria for development of CBWTF have been discussed in detail in the Previous sections. However, to have at a glance check in developing CBWTF, checklist is reproduced for convenience and is annexed (**Annexure-IV**).

**16) Periodic inspection/monitoring or performance evaluation of the CBWTF**

To have uniformity in performance evaluation of the CBWTF throughout the country, a check list for performance evaluation of the CBWTF for carrying out inspection/monitoring/compliance verification has been prepared and is annexed (**Annexure -V**). All the prescribed authority (SPCB/PCC) shall inspect the CBWTF at least once in six months located in the respective State/UT and a copy of the inspection reports shall be submitted to CPCB and MoEF & CC along with a copy of the action taken for ensuring compliance to the BMWM Rules and CPCB guidelines issued from time to time and also such information is required to be uploaded in SPCB/PCC website. CPCB shall carryout random inspection of the CBWTFs once in a quarter and any violations observed further actions shall be initiated by CPCB if required under the Environment (Protection) Act, 1986.

-- OO -

**Appendix-I****Methodology to Conduct gap analysis with respect to generation and treatment of biomedical waste - Revision 1**

Guidelines for Common Biomedical Waste Treatment Facilities was prepared by CPCB with an aim to have uniformity in ensuring site selection, allowing and establishment of a state-of-the-art Common Biomedical Waste Treatment Facilities (CBWTFs), operation as well as verification of compliance to the BMWM Rules, 2016 throughout the country. As per the said guideline, SPCB/PCC is required to prepare an inventory or review with regard to the bio-medical waste generation at least once in five years in the coverage areas of the existing CBWTF and conduct gap analysis as per format given in Annexure-I of the guideline.

Further, methodology for conducting gap analysis with respect to generation and treatment of biomedical waste prepared by CPCB and circulated to all SPCBs/PCCs. Accordingly, 12 SPCBs/PCCs have conducted gap analysis and submitted the report to CPCB. However, non-uniformity and ambiguity was observed specifically with regard to the method for extrapolating the data on biomedical waste generation and requirement of adequate treatment capacity in the gap analysis reports submitted by SPCBs/PCCs. Therefore, revised methodology have been prepared with an aim to have uniformity in the method for carrying out the gap analysis by State Pollution Control Boards/Pollution Control Committees.

The methodology for conducting gap analysis may be based on following parameters:

S. No.	Parameters	Details
1.	Coverage area of CBWTF	Mention farthest distance covered by CBWTF
2.	No. of HCFs (Bedded and non-bedded)	In Number
3.	No. of Beds covered	In Number
4.	Total biomedical waste generation (in Kg/day)	The generation of biomedical waste may be calculated by considering following aspects:  a) Generation from bedded HCFs: The biomedical waste generation rate may be considered as 277* grams per bed per day

		<p>b) Generation from non-bedded HCFs: The biomedical waste generation may be considered as 274** grams per day</p> <p>c) Biomedical waste generated from occasional waste generators such as health camps, institutions, vaccination camps etc as defined under CPCB guidelines may also be considered.</p> <p>* Reference: Report on Health-care Waste Management status in countries of the South-East Asia Region by WHO which is also nearly equal to the average biomedical waste generation per day per bed as per AR information received from States/UTs.</p> <p>**The value is taken based on the data given by CBWTF Associations regarding current average biomedical waste generation from non-bedded HCFs.</p>
5.	Extrapolate the biomedical waste generation for next 10 years	Linear method may be adopted for extrapolation of biomedical waste generation
6.	Total existing treatment capacity (in Kg/day) (Sum of Incineration Capacity and Autoclave/Microwave/Hydroclave Capacity)	<p>For calculation of existing treatment capacity, maintenance time (not more than 12-18 hrs/month) may be considered for calculating operational hours of equipment as below:</p> <p>a) Operational Hours for static incinerator 20 hrs/day</p> <p>b) Operational hours for Rotary incinerator 22 hrs/day</p> <p>c) 18 cycle per day for autoclave</p>

		The actual capacity may also be considered as 90% of available capacity keeping 10% margin for diverted/extra waste etc.
7.	Total Biomedical Waste treated and disposed (Kg/day)	Sum of all categories of biomedical waste treated and disposal.
8.	Gap between total extrapolated biomedical waste generation (for next 10 years) and existing biomedical waste treatment capacity	Extrapolated biomedical waste generation minus total existing treatment capacity

**Annexure-I**

**Coverage area-wise gap analysis for assessing additional BMW treatment capacity requirement**

S. No	Coverage area (pl. indicate areas covered by a CBWTF in the State/UT)	No. of HCFs		No. of Beds covered	Total estimated BMW generation in Kg/day	Total existing treatment capacity in Kg					Total BMW Treated and Disposed in Kg/day	Gap between total BMW Generation and the Existing BMW Treatment Capacity in Kg	Remarks (Whether additional Treatment Capacity is required or not )	
		Bedded	Non-bedded			Incineration	Autoclaving/ Hydroclaving /microwaving	Chemical disinfection	Deep burial	Any other mode of disposal			Yes	No
(1)	(2)	(3)	(4)	(5)	(6)	(7)	(8)	(9)	(10)	(11)	(12)	(13)	(14)	(15)

*Note: Above gap analysis coverage area-wise is required to be prepared once in five years and should be shown or depicted in a Map of State/UT.*

**Annexure- II**

**Format for maintaining the records by the CBWTF Operator alongwith the transportation Vehicle used for collection of bio-medical waste from the member HCFs**

Name of the CBWTF :  
 Address of the CBWTF with contact details :  
 Vehicle Registration Number (certificate to be carried by the vehicle driver) :  
 Route covered (indicate places) by the vehicle :

*Note: Above format is required to be maintained in duplicate both by the CBWTF Operator and the member HCF*

Date	Vehicle number and the Time of arrival of the vehicle	Vehicle meter readings in KM		Name of the HCF with address and the bar code number from whom waste collected	Category-wise quantity of bio-medical waste received in kg				Total BMW collected by the CBWTF		Name of the Vehicle driver with	Signatures	
		Initial	Final		Yellow	Red	Blue	Out dated medicines	White - waste sharps	Total No. of Bags		Total waste	Vehicle Driver
(1)	(2)	(3)	(4)	(5)	(6)	(7)	(8)	(9)	(10)	(11)	(12)	(13)	(14)

### Annexure - III Log book for Operating the Incinerator/Plasma Pyrolysis

Date	Time of operation of the Incineration		Quantity of hourly BMW charged in Kg (Total BMW charged in a day in Kg)	Temperature maintained in °C		Negative draft primary chamber (in mm of water column) (Pl. indicate range i.e., min. to max)	Pressure drop across APCD (in mm of water column) (Pl. indicate range i.e., min. to max)	pH level of scrubbed liquid used	Average values of flue gas analysis results (continuous online ) observed during the incineration/plasma pyrolysis process operation			Consumption of electricity/ Diesel whichever is applicable			Net Quantity of bio-medical waste received in Kg	Net Quantity of bio-medical Waste left over in a day (in Kg)		
	Start	End		Primary Chamber	Secondary Chamber				After scrubbing in stack gas	CO in mg/Nm <sup>3</sup>	O <sub>2</sub> in %	CO <sub>2</sub> in %	% combustion Efficiency	Power (Indicate meter reading) Initial reading			Final reading	Diesel in liters (pl. indicate daily or weekly diesel consumption)
(1)	(2)	(3)	(4)	(5)	(6)	(7)	(8)	(9)	(10)	(11)	(12)	(13)	(14)	(15)	(16)	(17)	(18)	(19)

*Note: Fill the details whichever is applicable*

### Log Book for Operating the Autoclave/Hydroclave

Date	Time of operation of the Autoclave or Hydroclave		Batch number	Quantity of waste per batch in Kg (Total waste treated by autoclaving/ hydroclave in Kg)	Temperature and Pressure in-every ten-minutes		Strip test result (pl. paste the strip test for each batch with a proof)	Consumption of electricity (indicate meter reading)		Net Quantity of waste received in Kg	Net Quantity of Waste left over in Kg
	Start	End			Temperature in °C	Pressure in psi		Initial reading	Final reading		
(1)	(2)	(3)	(4)	(5)	(6)	(7)	(8)	(9)	(10)	(11)	(12)=(11)-(5)

**Annexure – IV****Check List for Development of a Common Bio-medical Waste Treatment and Disposal Facility & For issuing 'Consent to Establishment under Water & Air Acts**

- 
1. Name of the Proponent :
  2. Proposed location of the CBWTF :
  3. No. of HCFs in the locality :
  4. No. beds :
  5. Total Bio-medical Waste Generation in kg/day :
    - (i) Incinerable in kg/day :
    - (ii) Autoclavable in kg/day :
    - (iii) Glass waste in kg/day :
    - (iv) Waste sharps in kg/day :
  
  6. **Proposed location of the CBWTDF:** located away from
    - a) Residential area : Yes  No
    - b) Sensitive area : Yes  No
    - c) Industrial area : Yes  No
    - d) Is it as a part of TSDF : Yes  No
    - e) Is the facility proposed in Hilly areas: Yes  No
    - d) Buffer distance of 500 m available : Yes  No
  
  7. **Proposed land area for CBWTF:**
    - a) Area about 1 acre : Yes  No
    - b) Area less than 1 Acre : Yes  No
    - c) Area more than 1 Acre : Yes  No
  
  8. **Proposed coverage area of the CBWTF:**
    - a) Any facility located upto a radius of 75 KM from the proposed locality : Yes  No
    - b) No. of beds covered by the existing facility/proposed facility:
      - (i) more than 10,000 beds : Yes  No
      - (ii) less than 10,000 beds : Yes  No
    - c) Is there any CBWTF within the radius of 75 KM : Yes  No
    - d) BMW Waste generation in a coverage area under consideration: ..... Kg/day
-

- e) Existing CBWTF treatment Capacity :
- (a) Incineration/plasma pyrolysis :..... Kg/day
- (b) Autoclave/hydroclave : .....Kg/day
- (c) Chemical Disinfection :..... Kg/day
- f) Is locality requires any additional capacity (within a radius of 75 KMs)?.
- : Yes  No
- (i) If so, indicate reason:.....

**9. Requirement of Treatment Facility:** Following treatment facilities shall be provided in a CBWTF:

- a) Incineration : Yes  No
- b) Autoclave (Pre-vacuum horizontal feeding) / Hydroclave / Microwave. : Yes  No
- c) Shredder : Yes  No
- d) Sharp pit (with drawing details) : Yes  No
- e) Provision for floor washing/vehicle washing: Yes  No
- f) Effluent Treatment Plant : Yes  No
- g) Secured land fill/Disposal of ash in TSDF : Yes  No
- h) Other provisions as per CPCB guidelines : Yes  No

**10. Segregation**

- (i). Segregation shall be as per the Bio-medical Waste Management Rules, 2016 as amended as well as compatible with treatment facilities at CBWTF
- (ii). Occupier/Generator is responsible for providing segregated waste to the operator.

**11. Collection**

- (i) Respective coloured bags provided with bar code should be kept in similar coloured container i.e. coloured bags shall not be directly kept in vehicle.
- (ii) Sharps shall be collected in puncture resistant, leak proof, rigid containers.
- (iii) Temporary storage at healthcare unit shall be designated.

**12. Transport Vehicle**

- 
- (I) Dedicated vehicles for collection of Bio-medical waste : Yes  No
  - (II) Separate cabins shall be provided for driver/staff and the bio-medical waste containers : Yes  No
  - (III) The base of the waste cabin shall be leak proof to avoid pilferage of liquid during transportation : Yes  No
  - (I) The waste cabin may be designed for storing waste containers in tiers : Yes  No
  - (V) The waste cabin shall be so designed that it is easy to wash and disinfect. : Yes  No
  - (VI) The inner surface of the waste cabin shall be made of smooth surface to minimize water retention :Yes  No
  - (VII) The waste cabin shall have provisions of sufficient openings in the rear and/or sides so that waste containers can be easily loaded and unloaded : Yes  No
  - (VIII) The vehicle shall be labeled with the bio-hazard symbol (as per Schedule IV of BMW Rules) and should display the name, address and telephone number of the CBWTF : Yes  No
  - (IX) Other provision as per CPCB guidelines : Yes  No

### 13. Storage

- (I) Sufficient ventilated storage space for untreated and treated bio-medical waste shall be provided. : Yes  No
- (II) The flooring and walls (to a height of 2M from floor) shall be finished with smooth and fine material. There shall be minimum number of joints. : Yes  No

### 14. Record Keeping

- (I) Documents such as collection advice taken from health care units for each category of waste, records of waste movements, logbook for the equipment and site records shall be maintained. : Yes  No
- (II) All the record (five year) shall be available at the CBWTF site for inspection. : Yes  No

### 15. Proposed Treated Waste Disposal method:

- (i). Incineration ash - Secured landfill/near by TSDF : Yes  No
-

- (ii). Plastic waste after disinfection and shredding –Registered Recycling Unit  
: Yes  No
- (iii). Sharps, after disinfection ( if encapsulated ) - Municipal landfill  
: Yes  No
- (iv). Treated wastewater –Discharge into sewer/drain or recycling in APCD  
: Yes  No
- (v). Oil & grease –By incineration: : Yes  No
- (VI). Any other mode of disposal of recyclable waste:  
(If so, pl. indicate .....)

**16. Estimated energy consumption and fuel consumption per month :**

- (i) Estimated energy consumption per month
- (a) General lighting in the facility :  
(b) Incinerator :  
(c) Autoclave/microwave :  
(d) Shredder :  
(e) ETP :  
(f) Any other :
- (ii) Estimated fuel consumption:
- (a) Diesel consumption :..... in KI per month  
(b) No. of hours of operation of DG Set :  
(c) No. of hours of incineration :

17. Whether the proponent obtained necessary approvals from the concerned departments as required : Yes  No

(i) If yes, attach details

18. Whether the proponent obtained EC as per EIA 2006 and the amendments made thereof : Yes  No

(i) If yes, attach a copy of the EC obtained from the concerned

19. Whether the proposal recommended for issuing consent to establish

---

: Yes  No

**(Signature of the official verified with date)**

## Annexure – V

**Check List for Performance Evaluation of the  
Common Bio-medical Waste Treatment and Disposal Facility (CBWTF)**

S.No.	Details		Particulars
01.	Name of CBWTF with contact details	:	
02.	Date of visit	:	
03.	Location details of the CBWTF	:	a) Near to Residential area: :Yes <input type="checkbox"/> No <input type="checkbox"/> b) In/near Sensitive area: Yes <input type="checkbox"/> No <input type="checkbox"/> c) In Industrial area : Yes <input type="checkbox"/> No <input type="checkbox"/> d) Is there a buffer zone of 500 m: Yes <input type="checkbox"/> No <input type="checkbox"/> Indicate exact distance:                    in KM e) Is it as a part of TSDF: Yes <input type="checkbox"/> No <input type="checkbox"/> If so, distance of TSDF from the nearest CBWTF: .....KM.. f) Is the facility proposed in Metropolitan city: Yes <input type="checkbox"/> No <input type="checkbox"/> (i)Name of the City: ..... (ii)Population of the City (as per latest census): ..... g) Is the facility proposed in Hilly area : Yes <input type="checkbox"/> No <input type="checkbox"/> (i)Name of the Town/City: .....
04	Month / year of establishment and the Consents status	:	Establishment Month/Year :
05.	CBWTF set up by	:	
06.	CBWTF operated by	:	
07.	Total number of healthcare facilities and beds covered (as on date of visit)	:	No. of HCFs : No. of Beds : No. of HCFs and beds upto 75 KM radius:

S.No.	Details	Particulars
08.	Total BMW Treatment Capacity of CBWTF (in kg / day)	Incineration : Autoclave : Chemical Disinfection: Any other treatment and disposal:
09.	<b>Consents and Authorization details :</b>	
9.1	Consent under Water (Prevention and Control of Pollution) Act, 1974	<input type="checkbox"/> Applied for <input type="checkbox"/> Not Applied for <input type="checkbox"/> Possess Valid Consent <input type="checkbox"/> Not renewed <input type="checkbox"/> No consent If obtained: Consent is valid upto ..... and issued by .....SPCB/PCC vide letter dated .....
9.2	Consent under Air (Prevention and Control of Pollution) Act, 1981	<input type="checkbox"/> Applied for <input type="checkbox"/> Not Applied for <input type="checkbox"/> Possess Valid Consent <input type="checkbox"/> Not renewed <input type="checkbox"/> No consent If obtained: Consent is valid upto ..... and issued by .....SPCB/PCC vide letter dated .....
9.3	<b>Environmental Clearance ( EC)</b>	<input type="checkbox"/> Applied for <input type="checkbox"/> Not applied <input type="checkbox"/> Obtained <input type="checkbox"/> Not obtained If obtained: EC issued by SEIAA or MoEF& CC vide letter dated .....
9.4	Authorization under BMW Rules, 1998	<input type="checkbox"/> Applied for <input type="checkbox"/> Not Applied for <input type="checkbox"/> Possess Valid Authorisation <input type="checkbox"/> Not renewed <input type="checkbox"/> No Authorisation If obtained: Authorisation is valid upto ..... and issued by .....SPCB/PCC vide letter dated .....
10.	Investment in setting up the CBWTF	
11.	Area of plot size for CBWTF (Sq. ft.)	
12	Annual Report submission for the year .....	Submitted before due date : :Yes <input type="checkbox"/> No <input type="checkbox"/> If yes, provide details of waste collected, received and treated & disposed of: .....
12.	Coverage area of CBWTF (radius in KM covered)	Coverage area upto 75 km radius: Yes <input type="checkbox"/> No <input type="checkbox"/>

S.No.	Details	Particulars
13.	Name of Districts/Cities / places being covered	(Pl. indicate Districts or places covered:..... .....) W.r.to the CBWTF (i) Farthest HCF located at :.....KM (ii) Nearest HCF located at :.....KM.
14.	Daily operation schedule (timings)	(i) Collection: ...AM to ... PM. (ii) Incineration:....AM to ...PM (iii) Whether waste from member HCFs collected in holidays: <input type="checkbox"/> Yes <input type="checkbox"/> No
15.	Cost charged to the healthcare facilities	(i) Charges in Rs..... (ii) Is the cost to be levied suggested by: .....Organisation
<b>16.</b>	<b>Total quantity of bio-medical waste treated: kg/day (avg.)</b>	
16.1	Incinerable	: ..... %
16.2	Autoclaving	: .....%
16.3	Chemical Disinfection	: .....%
16.4	Others (please specify waste type-wise)	: .....%
<b>17.</b>	<b>Staff involvement in CBWTF operation (number of persons):</b>	
17.1	Managerial Administration	/ :
17.2	Equipment operations	:
17.3	Transportation of BMW	: No. of Drivers: No. of Helpers:
17.4	Sanitation and others	:
17.5	Total persons excluding managers	:
<b>18.0</b>	<b>Collection and Transportation of bio-medical waste from member HCFs :</b>	
18.1	No. of Vehicles used for collection of waste from member HCFs	: (i) Four Wheelers: .....Nos and Vehicle Numbers: ..... (ii) Two Wheelers :.....Nos and Vehicle Numbers:.....
18.2	Vehicles are labeled as per BMW Rules, 2016	: <input type="checkbox"/> Satisfactory <input type="checkbox"/> No satisfactory
18.3	Vehicles used are as per CPCB Guidelines	: <input type="checkbox"/> Satisfactory <input type="checkbox"/> No satisfactory

S.No.	Details	Particulars												
18.4	Vehicles attached with the GPS provision as per BMWM Rules 2016	<input type="checkbox"/> Satisfactory <input type="checkbox"/> No satisfactory												
18.5	Whether waste collected from member HCFs adopted Bar coding system ?	<input type="checkbox"/> Yes <input type="checkbox"/> No												
<b>19.0</b>	Temporary untreated waste storage area	<input type="checkbox"/> Satisfactory <input type="checkbox"/> No satisfactory												
<b>20.0</b>	Mode of conveyance of bio-medical waste from untreated waste storage area to the treatment equipment within the CBWTF	<input type="checkbox"/> Closed Trolley/Pull cart with bio-hazard symbol <input type="checkbox"/> No Closed Trolley/Pull cart <input type="checkbox"/> Others like .....												
<b>21.0</b>	<b>Treatment equipment installed at CBWTF</b>													
21.1	Incinerator/plasma pyrolysis capacity and make	(i) No. of Incinerators including standby: (ii) Incineration capacity: ..... kg /hr .....Kg/day.												
21.2	Daily Operation schedule of the incinerator /plasma pyrolysis (timings)	.....AM to .....PM (or) .....PM to .....AM Whether bio-medical waste collected from member HCFs is treated during holidays: Yes <input type="checkbox"/> No <input type="checkbox"/>												
21.3	Consumption of auxiliary fuels	<table border="1"> <thead> <tr> <th>S. No</th> <th>Type of Fuel</th> <th>Consumption Quantity in liters per day</th> <th>Bill numbers of purchase of fuel</th> </tr> </thead> <tbody> <tr> <td>a)</td> <td></td> <td></td> <td></td> </tr> <tr> <td>b)</td> <td></td> <td></td> <td></td> </tr> </tbody> </table>	S. No	Type of Fuel	Consumption Quantity in liters per day	Bill numbers of purchase of fuel	a)				b)			
S. No	Type of Fuel	Consumption Quantity in liters per day	Bill numbers of purchase of fuel											
a)														
b)														
21.4	Stack attached with the incinerator /plasma pyrolysis	<b>(i)</b> Stack Diameter:    m <b>(ii)</b> Stack Height :    m above Ground Level												
21.5	Monitoring provision attached with the stack	<input type="checkbox"/> Platform <input type="checkbox"/> Porthole <input type="checkbox"/> access to the platform (Steps/Monkey Ladder/any other.....)												
21.6	Is stack monitoring provision satisfactory	<input type="checkbox"/> Yes <input type="checkbox"/> No												

S.No.	Details	Particulars
	and as per CPCB guidelines	
21.7	air pollution control systems attached with the incinerator/plasma pyrolysis	: (i) Quenching : <input type="checkbox"/> Yes <input type="checkbox"/> No (ii) Venturi scrubber : <input type="checkbox"/> Yes <input type="checkbox"/> No (iii) Droplet separator : <input type="checkbox"/> Yes <input type="checkbox"/> No (iv) Mist eliminator : <input type="checkbox"/> Yes <input type="checkbox"/> No (v) Filters : <input type="checkbox"/> Yes <input type="checkbox"/> No (vi) Lime and Activated Carbon injection: : <input type="checkbox"/> Yes <input type="checkbox"/> No (vii) ID Fan : <input type="checkbox"/> Yes <input type="checkbox"/> No (viii) Any other : (Pl. indicate)
21.8	Waste feeding mechanism	: (i) Manual feeding : <input type="checkbox"/> Yes <input type="checkbox"/> No (ii) PLC based Automatic feeding : <input type="checkbox"/> Yes <input type="checkbox"/> No
21.9	Is PLC and automatic recording system (for recording operating parameters of the incinerator) attached with the incinerator/plasma pyrolysis	: (i) PLC synchronized with waste feeding mechanism & in working condition: <input type="checkbox"/> Yes <input type="checkbox"/> No (II) PLC synchronized and recording system attached with incinerator and in working condition: <input type="checkbox"/> Yes <input type="checkbox"/> No
21.10	Operational conditions of the Incineration/plasma pyrolysis as observed during the visit	: (i) Whether burners in working condition: <input type="checkbox"/> Yes <input type="checkbox"/> No (ii) Temperature maintained in Primary Chamber (range) : ..... <sup>o</sup> C (iii) Temperature maintained in Secondary Chamber (range):..... <sup>o</sup> C (iv) Negative draft in Primacy Chamber : .....mm of water column (v) Pressure drop in the Venturi: ..... mm of water column
21.11	Is continuous on-line monitoring system/Flue gas analyser attached with the incinerator/plasma pyrolysis for flue gas	: (i) Is continuous online monitoring system (COMS) attached with incinerator: <input type="checkbox"/> Yes <input type="checkbox"/> No (ii) Observed values of flue gas parameters: CO <sub>2</sub> : .%; O <sub>2</sub> : ..... % and CO: ..... % (iii) Observed Combustion Efficiency: .....%

S.No.	Details	Particulars
	analysis (i.e CO, O <sub>2</sub> and CO <sub>2</sub> )	(iv) Observed values of stack emissions as per COMS .....
21.12	Emergency and Fire safety measures adopted within the facility is adequate	: Is Emergency stack attached with the incinerator: <input type="checkbox"/> Yes <input type="checkbox"/> No Whether fire safety measures adopted (Fire Extinguishers, Sand buckets etc.): <input type="checkbox"/> Yes <input type="checkbox"/> No
21.13	Log book for incinerator/ plasma pyrolysis is maintained and satisfactory	: Log Book Maintained: <input type="checkbox"/> Yes <input type="checkbox"/> No Log Book Maintained is satisfactory : <input type="checkbox"/> Yes <input type="checkbox"/> No
21.14	Details of heat recovery system installed with incinerator/plasma pyrolysis	: <input type="checkbox"/> Yes <input type="checkbox"/> No
<b>22.0</b>	<b>Capacity of autoclave and-- make</b>	: Autoclave of capacity .....kg/cycle and make ..... installed.
22.1	Operating conditions of autoclave/microwave as observed during the visit	: Operating parameters observed: (i) Temperature : in °C (ii) Pressure : in psi (iii) Residence time : in minutes
22.2	Provision made for the autoclave /microwave	: Trolley for waste feeding : <input type="checkbox"/> Yes <input type="checkbox"/> No Graphic or computer recording device attached: <input type="checkbox"/> Yes <input type="checkbox"/> No
22.3	Spore test or strip test conducted regularly and records maintained	: <input type="checkbox"/> Yes <input type="checkbox"/> No Pl. indicate frequency of Strip test conducted: every batch /once in a week /quarterly /yearly Pl. indicate frequency of Spore test conducted: every batch /once in a week /quarterly /yearly
22.4	Performance of autoclave by spore testing or routine test	: <input type="checkbox"/> Satisfactory <input type="checkbox"/> Not satisfactory
22.5	Log book maintained for autoclave is satisfactory	: Log Book Maintained: <input type="checkbox"/> Yes <input type="checkbox"/> No Log Book Maintained is satisfactory : <input type="checkbox"/> Yes <input type="checkbox"/> No
<b>23.0</b>	<b>Capacity of shredder and make</b>	: ..... kg/hr. Self-designed & got fabricated locally.

S.No.	Details	Particulars														
24.0	Details of sharp pit / Encapsulation facility :	(i) Sharp Pit provided : <input type="checkbox"/> Yes <input type="checkbox"/> No (ii) Is it as per CPCB guideline : <input type="checkbox"/> Yes <input type="checkbox"/> No (iii) Records maintained : <input type="checkbox"/> Yes <input type="checkbox"/> No (iv) Total quantity of waste sharps stored: (v) Total quantity of waste sharps treated and disposed:														
<b>25.0</b>	<b>Water Balance</b>															
25.1	Source and quantity of water intake per day (cu.m / day) :	Water consumption source: ..... Water is drawn at ..... KLD approximately. Is magnetic water flow meter attached to the water source/water storage tank : <input type="checkbox"/> Yes <input type="checkbox"/> No  Magnetic water flow meter readings as per record (for last month): 1 <sup>st</sup> Day of Month : Last day of month : Magnetic Flow meter as observed during the visit: <table border="1" style="margin-left: 20px;"> <thead> <tr> <th rowspan="2">S. No</th> <th rowspan="2">Month</th> <th colspan="2">Magnetic flow meter reading</th> </tr> <tr> <th>Initial</th> <th>Final</th> </tr> </thead> <tbody> <tr> <td>(1)</td> <td>Previous month .....</td> <td></td> <td></td> </tr> <tr> <td>(2)</td> <td>On the date of visit:.....</td> <td></td> <td></td> </tr> </tbody> </table> If water requirement is met from outside through tankers, pl. provide No. of Tankers procured in a previous six months:  Total quantity of water consumed during the previous six months : .. .... in KLD	S. No	Month	Magnetic flow meter reading		Initial	Final	(1)	Previous month .....			(2)	On the date of visit:.....		
S. No	Month	Magnetic flow meter reading														
		Initial	Final													
(1)	Previous month .....															
(2)	On the date of visit:.....															
25.2	Break up of water usage (such as washing, scrubbing etc.) :	Scrubber – KL/hr or KLD Washing – KLD Disinfections – KLD Gardening – KLD Domestic – KLD														

S.No.	Details	Particulars
26.0	Total wastewater effluent generated per day	: About .....KLD generated Quantity of treated water reused/recycled in %: Any other mode of disposal:
27.	<b>Effluent treatment plant details</b>	
27.1	ETP Capacity	: ..... KL/Cycle
27.2	Flow Chart of ETP	: ETP comprising of: ..... Unit operations
27.3	Intake and Discharge of ETP	: (i) Magnetic Flow measuring device provided at the outlet of ETP: <input type="checkbox"/> Yes <input type="checkbox"/> No (ii) Energy meter attached to the ETP: <input type="checkbox"/> Yes <input type="checkbox"/> No (iii) Energy consumed over a period of one month: = ..... Units (iv) pH meter attached at the outlet of ETP: <input type="checkbox"/> Yes <input type="checkbox"/> No
27.4	Final mode of disposal of treated water	: (i) Is treated wastewater complying with the discharge norms <input type="checkbox"/> Yes <input type="checkbox"/> No (ii) Is Treated water is reused in the scrubber: <input type="checkbox"/> Yes <input type="checkbox"/> No (ii) Is Treated water is reused for gardening: <input type="checkbox"/> Yes <input type="checkbox"/> No (iii) Is Treated water is discharged in drain: <input type="checkbox"/> Yes <input type="checkbox"/> No (iv) Is Treated water is discharged in open area: <input type="checkbox"/> Yes <input type="checkbox"/> No
28.	<b>Status of infrastructure provided (Pl. indicate 'Yes / No' whichever is applicable)</b>	
28.1	Separate treatment equipment room	: <input type="checkbox"/> Yes <input type="checkbox"/> No
28.2	Main waste storage room	: <input type="checkbox"/> Yes <input type="checkbox"/> No
28.3	Treated waste storage room	: <input type="checkbox"/> Yes <input type="checkbox"/> No
28.4	Administrative room	: <input type="checkbox"/> Yes <input type="checkbox"/> No
28.5	Generator set	: <input type="checkbox"/> Yes <input type="checkbox"/> No

S.No.	Details		Particulars
	(i) Capacity	:	
	(ii) Is Stack attached as per DG Set norms	:	<input type="checkbox"/> Yes <input type="checkbox"/> No
	(iii) Is Acoustic enclosure provided as per DG Set norms	:	<input type="checkbox"/> Yes <input type="checkbox"/> No
	(iv) Is DG Set complying to the emissions norms and noise level norms	:	<input type="checkbox"/> Yes <input type="checkbox"/> No  If so, pl. indicate latest monitoring results: .....
28.6	Site security (high walls, fencing, guarded gates etc.)	:	High walls on all four sides : <input type="checkbox"/> Yes <input type="checkbox"/> No Fencing on all the sides    : <input type="checkbox"/> Yes <input type="checkbox"/> No Guarded Gates                : <input type="checkbox"/> Yes <input type="checkbox"/> No Any other observation pl indicate:.....
28.7	Parking facility	:	<input type="checkbox"/> Yes <input type="checkbox"/> No
28.8	Sign board	:	<input type="checkbox"/> Yes <input type="checkbox"/> No
28.9	Green belt	:	<input type="checkbox"/> Yes <input type="checkbox"/> No
28.10	Washing room	:	<input type="checkbox"/> Yes <input type="checkbox"/> No
28.11	First aid box	:	<input type="checkbox"/> Yes <input type="checkbox"/> No
28.12	Lighting arrangements in the facility	:	<input type="checkbox"/> Yes <input type="checkbox"/> No
28.13	Odour problem remedial measures	:	<input type="checkbox"/> Yes <input type="checkbox"/> No
28.14	Fire fighting and emergency facilities	:	<input type="checkbox"/> Yes <input type="checkbox"/> No
28.15	Measures for control of pests / insects etc.	:	<input type="checkbox"/> Yes <input type="checkbox"/> No
28.16	Protective gear for waste handlers	:	<input type="checkbox"/> Yes <input type="checkbox"/> No
28.17	Telephone facility	:	<input type="checkbox"/> Yes <input type="checkbox"/> No
28.18	Provision of washing, toilets and safe place for eating for the workers	:	<input type="checkbox"/> Yes <input type="checkbox"/> No
28.19	Fire alarm system provided in the facility	:	<input type="checkbox"/> Yes <input type="checkbox"/> No

S.No.	Details	Particulars
<b>29.</b>	<b>Record maintenance and record keeping details (Pl. indicate 'Yes / No' whichever is applicable)</b>	
29.1	Waste Movement /Manifest record :	<input type="checkbox"/> Yes <input type="checkbox"/> No
29.2	Log book for treatment equipment :	<input type="checkbox"/> Yes <input type="checkbox"/> No
29.3	Site records :	<input type="checkbox"/> Yes <input type="checkbox"/> No
29.4	Incineration ash generation and final disposal records :	<input type="checkbox"/> Yes <input type="checkbox"/> No
29.5	Treated plastic waste generation and its sale to the registered recycler :	<input type="checkbox"/> Yes <input type="checkbox"/> No
29.6	Syringes treated and its final disposal record :	<input type="checkbox"/> Yes <input type="checkbox"/> No
29.7	Workers health status records :	<input type="checkbox"/> Yes <input type="checkbox"/> No
29.8	Workers immunization records :	<input type="checkbox"/> Yes <input type="checkbox"/> No
29.9	Medical and para-medical workers training records :	<input type="checkbox"/> Yes <input type="checkbox"/> No
29.10	Whether records maintained with regard to the accidents ( such as fire, spills and injury and measures taken) :	<input type="checkbox"/> Yes <input type="checkbox"/> No
<b>30.</b>	<b>Collection and transportation status (Yes / No)*</b>	
30.1	Whether waste collected in a container of similar colour with label as per the Rules? :	<input type="checkbox"/> Yes <input type="checkbox"/> No
30.2	Whether the person who collects BMW maintain a register with him / her? :	<input type="checkbox"/> Yes <input type="checkbox"/> No

S.No.	Details		Particulars
30.3	Has due attention have been given in vehicles to prevent spillage / pilferage/ loading / unloading etc.?	:	<input type="checkbox"/> Yes <input type="checkbox"/> No
30.4	Is the vehicle labeled with the symbol and display the name, address, telephone number etc.?	:	<input type="checkbox"/> Yes <input type="checkbox"/> No
30.5	Does the CBWTF operator use satellite station to store the waste?	:	<input type="checkbox"/> Yes <input type="checkbox"/> No (If yes, give details.....)
30.6	The CBWTF operator collects waste daily or alternate day including holidays?	:	<input type="checkbox"/> Yes <input type="checkbox"/> No
30.7	Whether waste treatment criterion of 48 hours is complied?	:	<input type="checkbox"/> Yes <input type="checkbox"/> No
<b>31.</b>	<b>Disposal of treated waste:</b>		
31.1	Plastic waste after treatment	:	Plastic waste Sold to: M/s. .... and approved by .....SPCB/PCC
31.2	Treated sharps	:	Treated syringes disposal by:..... or through M/s.....and approved by .....SPCB/PCC
31.3	Incineration ash	:	Incineration ash disposal by: Disposal in Sanitary Landfill: <input type="checkbox"/> Yes <input type="checkbox"/> No Disposal through TSDF: <input type="checkbox"/> Yes <input type="checkbox"/> No Any other mode :.....
31.4	Other treated solid wastes	:	
31.5	Oil & grease	:	
31.6	Treated wastewater	:	

S.No.	Details	Particulars																					
32.	Frequency of incinerator / autoclave / microwave / hydroclave / ETP discharge effluent testing and name of the laboratory (specify approved or not under E(P) Act, 1986 or NABL Accredited Lab.). Give details of compliance / non-compliance)	(i) Reported monitoring frequency: (ii) Stack monitoring : Quarterly : <input type="checkbox"/> Yes <input type="checkbox"/> No (iii) Waste water : Monthly/Quarterly/Yearly (iv) Incineration ash : Monthly/Quarterly/Yearly (v) Name of the Laboratory conducted test: ..... (vi) Is the Laboratory approved under E (P) Act, 1986/.....SPCB/PCC/ NABL: <input type="checkbox"/> Yes <input type="checkbox"/> No (vii) Copies of the analysis reports of treated effluent, incinerated ash, stack monitoring as (Annexures.....)																					
32.1	Frequency of site inspection by SPCBs/PCCs/CPCB/any other agencies	(i) No. of times in a year inspected by the SPCB/PCC: ..... (ii) No. of times in a year inspected by the CPCB .....																					
<b>33.</b>	<b>Monitoring Results :</b>																						
33.1	Incinerator stack emission (parameters stipulated in the Rules, temperature attainment in the chambers, residence time in the secondary chamber etc.)	<table border="1"> <thead> <tr> <th>Parameter</th> <th>PM</th> <th>HCl</th> <th>NO<sub>x</sub></th> <th>Hg &amp; com-pounds</th> <th>Dioxins and Furans</th> <th>C.E.</th> </tr> </thead> <tbody> <tr> <td>Date</td> <td></td> <td></td> <td></td> <td></td> <td></td> <td></td> </tr> <tr> <td>LIMIT</td> <td>50</td> <td>50</td> <td>400</td> <td>0.05</td> <td>0.1 ng per Nm<sup>3</sup></td> <td>99.00%</td> </tr> </tbody> </table> Date of monitoring: Note: All values are in mg/Nm <sup>3</sup> , except CE	Parameter	PM	HCl	NO <sub>x</sub>	Hg & com-pounds	Dioxins and Furans	C.E.	Date							LIMIT	50	50	400	0.05	0.1 ng per Nm <sup>3</sup>	99.00%
Parameter	PM	HCl	NO <sub>x</sub>	Hg & com-pounds	Dioxins and Furans	C.E.																	
Date																							
LIMIT	50	50	400	0.05	0.1 ng per Nm <sup>3</sup>	99.00%																	
33.2	Whether Stack emission norms are complied with by the CBWTF	<input type="checkbox"/> Yes <input type="checkbox"/> No																					
33.3	Incineration ash characteristics	Characteristics as per Schedule –II of HOW (M& TM) Rules,2016 ( Annexure-----) Is it hazardous waste as per HOWM&TM Rules, 2016: <input type="checkbox"/> Yes <input type="checkbox"/> No																					
33.4	ETP inlet/outlet characteristics	<table border="1"> <thead> <tr> <th>Parameter</th> <th>pH</th> <th>TSS</th> <th>COD</th> <th>BOD</th> <th>O&amp;G</th> </tr> </thead> <tbody> <tr> <td>ETP Inlet Result</td> <td></td> <td></td> <td></td> <td></td> <td></td> </tr> </tbody> </table>	Parameter	pH	TSS	COD	BOD	O&G	ETP Inlet Result														
Parameter	pH	TSS	COD	BOD	O&G																		
ETP Inlet Result																							

S.No.	Details		Particulars					
			ETP Result	Outlet				
			All values are in mg/l except pH					
33.5	Whether liquid effluent discharge norms are complying by the CBWTF	:	<input type="checkbox"/> Yes <input type="checkbox"/> No					
33.6	Whether CBWTF is submitting the annual report within the due date for the preceding year	:	<input type="checkbox"/> Yes <input type="checkbox"/> No If Yes, annual report submitted vide letter No..... dated.....					
34.	Any other relevant observations	:	(pl. enclose as annexure)					
35.	Name of the officials with designation inspected /monitored the CBWTF and the signature	:						

## Annexure-VI

### STATIONARY SOURCE EMISSION MONITORING

#### MODIFICATIONS TO BE MADE TO SAMPLING PLATFORM AND SAMPLING PORT HOLE

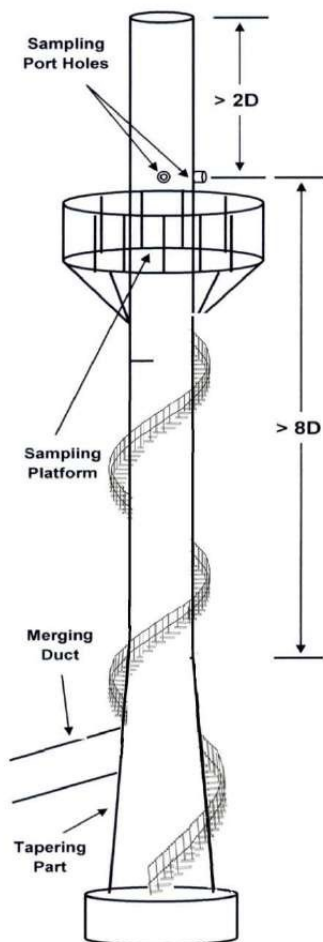

**Number of Port Holes :** Minimum two numbers of Port Holes at 90° apart from each other at a horizontal plane.

**Location of Port Holes :** Minimum 8 times of Internal Diameters of Stack downstream (upward direction of stack) from any duct confluence, bends and tapering & minimum 2 times of Internal Diameters of Stack upstream (downward direction of stack) from stack exit.

**Location of Sampling Platform :** 5 feet upstream (downward direction of stack) from the Port Hole as determined above.

**Port Hole Flange :** If the internal diameter of the flange is 4 inch or more then there is no need to change, if it is less than 4 inch than it has to be replaced with 4 inch flange. The flange should not protrude out more than 6 inches from the outer wall of the stack (it shall be kept as less as possible).

**Sampling Platform Modification :** A semi-circular extension of the existing platform (width extending outward by 6 feet from outside wall of the stack and covering at least one third of the circumference) may be provided for access to both the Port Holes. This area can be extended from the existing Platform and if deemed necessary for safety of the personnel a counter extension in opposite direction may also be provided. The extended Platform shall be strengthened with requisite support from the stack.

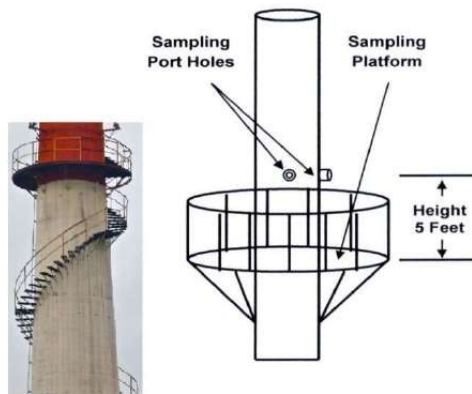

Note: Alternatively, safe access to monitoring platform may be provided with separate scaffolding-cum-staircase arrangement

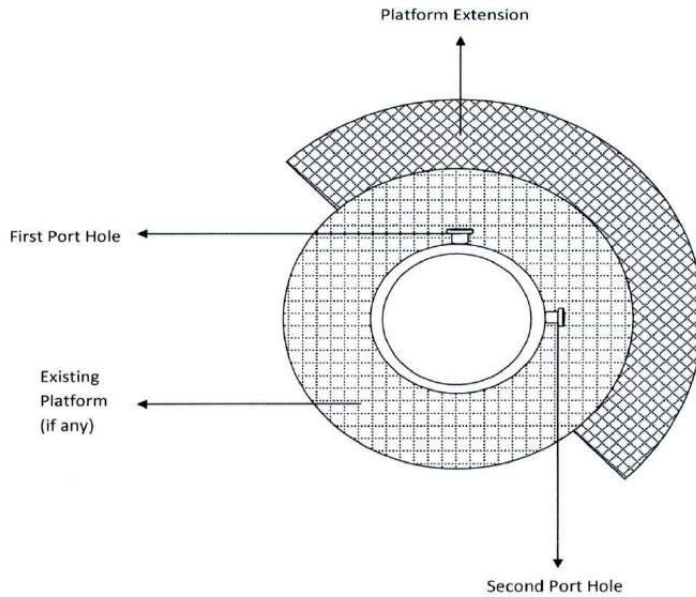

**Sampling Platform Modification / Extension**

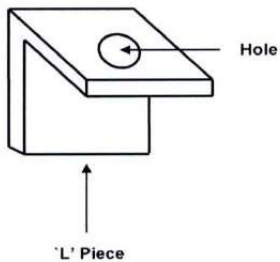

**Fixing of 'L' Pieces on the stack wall :** Two 'L' shaped pieces are to be fixed on the stack wall for mounting the Mono-Rail & Chain (part of the Sampling Kit for movement of sampling Train in & out through the Sampling Port Hole). The 'L' pieces shall be made of approximately 6 mm thick galvanized iron to have 5 cm long arms. One arm of the 'L' piece shall be welded on the stack wall and another arm shall have a hole of 14 mm diameter near the open end. Both the 'L' Pieces shall be welded on the stack wall at specified distances (as shown in the diagram on the next page) from the centre of Sampling Port Hole (in a vertical axis on the Stack Wall).

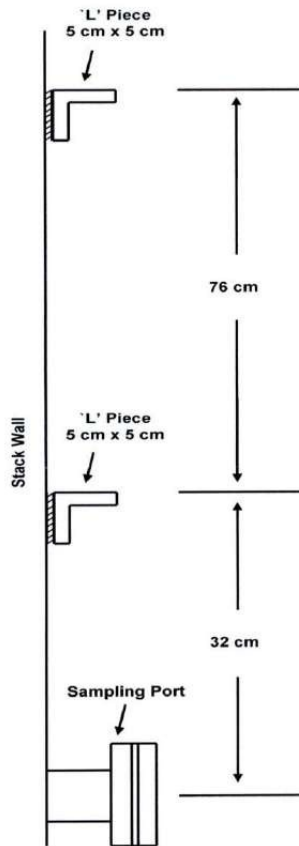

Fixing of 'L' Pieces on the Stack Wall

**ANNEXURE – VII**

The vehicle shall be labeled with the bio-hazard symbol (as per Schedule IV of the BMWM Rules) and should display the name, address and contact telephone and mobile number of the CBWTF.

**Bio Medical Waste Vehicle**

**Name and address of CBWTF with Contact number of CBWTF operator**

Authorized by *(Name of)* State Pollution Control Board/Pollution Control Committee

**Vehicle Side-1****Bio Medical Waste Vehicle**

**Name and address of CBWTF with Contact number of CBWTF operator**

Authorized by *(Name of)* State Pollution Control Board/Pollution Control Committee

**Vehicle Side-2****Bio- Hazard symbol at back side of the vehicle**

*Note: Proportion of Font size with respect to body height of the vehicle-12:1 (Minimum)*

*Proportion of Bio-hazard symbol with respect to body height of the vehicle-12:3 (Minimum)*

*Example: If body height is 6 feet i.e. 72" then minimum font size will be 6" and minimum size of bio-hazard symbol will be 18".*

---

**REFERENCES**

1. Bio-medical Waste Management Rules, 2016.
2. Revised Guidelines for Common Bio-medical Waste Treatment Facilities (2016).
3. CPCB Guidelines for BMW Incinerators.
4. 'Disposal of Bio-medical Waste generated during Universal Immunization Programme' issued by CPCB.
5. 'Guidelines for Environmentally Sound Management of Mercury Waste Generated from the Health Care Facilities' issued by CPCB.
6. Annual Report 2023 submitted to CPCB by the SPCBs/PCCs.
7. Stationary Source Emission Monitoring –Modifications to be made to the Sampling Platform and Sampling Port Hole issued by National Reference Trace Organics Laboratory (NRTOL), CPCB.

-- OO --

---

By Speed Post

F. No. B-31011-BMW (3398)-2023-WM-I

October 10, 2023

To,

The Member Secretary,  
All SPCB and PCC

4933-68

**Sub: Regarding methodology to conduct gap analysis with respect to generation and treatment of biomedical waste -reg.**

Sir/Madam,

It is to inform that State Pollution Control Boards/Pollution Control Committees are required to conduct gap analysis with respect to generation and treatment of biomedical waste in respective State/UT. A format for conducting gap analysis is given in CPCB guidelines for Common Bio-medical Waste Treatment Facilities. Few State Boards have prepared gap analysis report adopting their own methodology. The matter was also discussed in Central Monitoring Committee meeting on 18.07.2023 wherein need for adopting uniform methodology was emphasised. Hence, to avoid the ambiguity and to adopt uniform procedure, CPCB has prepared a methodology to conduct gap analysis (Copy attached herewith for ready reference).

In view of above, it is requested to kindly conduct gap analysis with respect to generation and treatment of biomedical waste in your State/UT using the aforesaid methodology and report may be submitted to CPCB within one month.

Yours faithfully,



(V. P. Yadav)

Director &amp; Head

Waste Management -I Division

Encl. As above

Copy to:

i. PS to 'MS'

: For kind information of 'MS' please



(V. P. Yadav)

केन्द्रीय प्रदूषण नियंत्रण बोर्ड  
निर्गत... MSingh %  
दिनांक 18/10/2023

## Methodology to Conduct gap analysis with respect to generation and treatment of biomedical waste

Guidelines for Common Biomedical Waste Treatment Facilities was prepared by CPCB with an aim to have uniformity in ensuring site selection, allowing and establishment of a state-of-the-art Common Biomedical Waste Treatment Facilities (CBWTFs), operation as well as verification of compliance to the BMWM Rules, 2016 throughout the country. As per the said guideline, SPCB/PCC is required to prepare an inventory or review with regard to the bio-medical waste generation at least once in five years in the coverage areas of the existing CBWTF and conduct gap analysis as per format given in Annexure-I of the guideline.

To avoid the ambiguity and maintaining the uniformity for conducting gap analysis a methodology is suggested for estimating generation, treatment of biomedical waste and its extrapolation in the State and coverage area of CBMWTF. It is elaborated in following table.

S. No.	Parameters	Details
1.	Coverage area of CBWTF	Up to 75 km
2.	No. of HCFs (Bedded and non-bedded)	In Number
3.	No. of Beds covered	In Number
4.	Total biomedical waste generation (in Kg/day)	The generation may be calculated considering following factors:  a) Generation from Bedded hospital  (in absence of availability of required information biomedical waste generation may be taken as 274 grams per bed)  b) Biomedical waste generated from non-bedded HCFs and other sources also be considered
5.	Extrapolate the biomedical waste generation for next years	Extrapolation may be based on factors such as population growth of the districts/cities covered by CBWTF, Rate of increase in number of HCFs/beds in past years etc. as decided by SPCB in consultation with Health department and CBMWTF associations.
6.	Total existing treatment capacity (in Kg/day) (Sum of Incineration Capacity and Autoclave/Microwave/Hydroclave Capacity)	For calculation of existing treatment capacity, maintenance time may be considered for calculating operational hours of equipment as below:  a) Operational Hours for static incinerator 20 hrs/day b) Operational hours for Rotary incinerator 22 hrs/day

		c) 18 cycle per day for autoclave  The actual capacity may be considered as 90% of available capacity keeping 10% margin for diverted/extra waste etc.
7.	Total Biomedical Waste treated and disposed (Kg/day)	Sum of all categories of biomedical waste treated and disposal.
8.	Gap between total extrapolated biomedical waste generation (for next 10 years) and existing biomedical waste treatment capacity	Extrapolate the biomedical waste generation minus total existing treatment capacity

Based on the above data, the gap between existing treatment capacity and need of additional treatment capacity should be examined after carrying out gap analysis at coverage area/city level and State level.

\*\*\*

By Speed Post

F. No. CP-23/19/2024-WM-I-HO-CPCB-HO-19160

December 12, 2024

To,

The Member Secretary,  
All SPCBs and PCCs**Sub:** Regarding methodology to conduct gap analysis with respect to generation and treatment of biomedical waste- Revision 1.

Sir/Madam,

This has reference to CPCB letter dated 10.10.2023 wherein methodology to conduct gap analysis with respect to generation and treatment of biomedical waste was forwarded to SPCBs/PCCs and requested to conduct gap analysis in line with the said methodology. (Name of State/UT) have submitted/ Not submitted the gap analysis report wherein gaps has been observed by CPCB. It was also observed that there is non-uniformity in the data and approach followed for conducting the gap analysis while extrapolating the data on biomedical waste generation. Therefore, the methodology has been revised and copy of the same is attached herewith for ready reference.

In view of above, it is requested to kindly revise / conduct gap analysis with respect to generation and treatment of biomedical waste in your State/UT using the aforesaid methodology and report may be submitted to CPCB within one month.

Yours faithfully,



(V. P. Yadav)

Director &amp; Head

Waste Management -I Division

Encl. As above

Copy to:

i. PS to 'MS'

: For kind information of 'MS' please



(V. P. Yadav)

केन्द्रीय प्रदूषण नियंत्रण बोर्ड  
निर्गत.....  
दिनांक... 23/12/24

o/c



केन्द्रीय प्रदूषण नियंत्रण बोर्ड  
CENTRAL POLLUTION CONTROL BOARD  
पर्यावरण, वन एवं जलवायु परिवर्तन मंत्रालय, भारत सरकार.  
MINISTRY OF ENVIRONMENT, FOREST & CLIMATE CHANGE, GOVT. OF INDIA.

By Registered Post

F. No. CP-23/78/2021-WM-I-HO-CPCB-HO- 19698

December 11, 2024

To,

The Chairman,  
(All SPCBs/PCCs)

**DIRECTION UNDER SECTION 5 OF THE ENVIRONMENT (PROTECTION) ACT, 1986 – FOR COMPLIANCE TO BIOMEDICAL WASTE MANAGEMENT RULES, 2016**

WHEREAS the Central Government has notified the Biomedical Waste Management Rules, 2016 (herein after referred as BMWM Rules, 2016) in suppression of the Bio-medical Waste (Management & Handling) Rules, 1998 and amendments thereof under the Environment (Protection) Act, 1986 to improve the collection, segregation, processing, treatment and disposal of the biomedical wastes in environmentally sound manner and thereby reducing its impact on the environment; and

WHEREAS as per Rule 9 (1) of BMWM Rules, 2016, "The prescribed authority for ensuring implementation of the provisions of Rules is the State Pollution Control Board (SPCB) in respect of State and Pollution Control Committee (PCC) in respect of Union territory"; and

WHEREAS as per Rule 10 of BMWM Rules, 2016, "Every occupier or operator handling bio-medical waste, irrespective of the quantity shall make an application in Form II to the prescribed authority for grant of authorisation and the prescribed authority shall grant the provisional authorisation in Form III and the validity of such authorisation for bedded health care facility and operator of a common facility shall be synchronised with the validity of the consents."; and

WHEREAS in the matter of Miscellaneous Application No. 98 of 2022 in Original Application No. 180 of 2021 titled Mukul Kumar Vs State of Uttar Pradesh & Ors., Hon'ble National Green Tribunal (Hon'ble NGT) reviewed implementation of BMWM Rules, 2016 in the country. In the said matter, Hon'ble NGT directed all States/UTs to submit report on implementation of BMWM Rules, 2016. Further, Central Pollution Control Board (CPCB) was directed to prepare a consolidated report indicating the compliance of various provisions of the BMWM Rules, 2016 by each State/UT. Accordingly, the as per the information submitted by SPCBs/PCCs, CPCB submitted the compiled report to Hon'ble NGT; and

WHEREAS Hon'ble NGT heard the aforesaid matter on 02.09.2024 and directed that CPCB shall update the report by taking updated information from all SPCBs/PCCs on implementation to BMWM Rules, 2016; and

WHEREAS CPCB has received updated information from 34 nos. of SPCBs/PCCs and while examining the reports it is observed that there are gaps in implementation of BMWM Rules, 2016 such as operating Health Care Facilities (HCFs) without having authorisation under BMWM Rules, 2016, action not being initiated against violating HCFs/CBWTFs, gap between biomedical waste generation and treatment, captive treatment facility (deep burial) in practice etc.; and

WHEREAS the Central Government vide notification S.O. 730 (E) dated July 10, 2002, has delegated the powers under Section 5 of the Environment (Protection) Act, 1986 to the Chairman, Central Pollution Control Board (CPCB), to issue directions for violation of the standards and rules relating to BMWM notified under the Environment (Protection) Act, 1986; and

'परिवेश भवन' पूर्वी अर्जुन नगर, दिल्ली - 110032.

Parivesh Bhawan, East Arjun Nagar, Delhi - 110 032.

दूरभाष /Tel : 43102030, 22305792, वेबसाइट/Website: www.cpcb.nic.in

NOW, THEREFORE, in exercise of the powers vested under Section 5 of the Environment (Protection) Act, 1986, it is directed herewith to:

- a. Initiate appropriate action immediately against the HCFs which are operational without having authorisation;
- b. Take appropriate action against HCFs and CBWTFs for violation of BMW Rules, 2016;
- c. Ensure that there is no gap in biomedical waste generation and treatment by ensuring adequate numbers/capacity of treatment facilities in the State/UT;
- d. Ensure deep burial disposal system is adopted by HCFs located only in rural or remote areas where there is no access to CBWTF with prior approval from SPCB/PCC and in compliance with standards prescribed under Schedule-III of BMW Rules, 2016;
- e. Submit gap analysis report to CPCB with respect to biomedical waste generation and treatment of biomedical waste;

Action taken report on above be submitted to the Central Pollution Control Board within 15 days from the date of receipt of these directions.

13/11/12

(Tanmay Kumar)  
Chairman

**Copy for information to:**

- i. The Additional Secretary, HSM Division,  
Ministry of Environment, Forest & Climate Change,  
Indira Paryavaran Bhawan,  
Jorbagh Road, New Delhi - 110 003. : For kind information
- ii. Regional Directorates CPCB : For kind information and follow-up  
(As per jurisdiction)
- iii. I/c IT Division : For information and necessary  
action



(Bharat Kumar Sharma)  
Member Secretary

